

# Approximation Modeling for the Online Performance Management of Distributed Computing Systems

Dara Kusic<sup>†</sup>, Nagarajan Kandasamy<sup>†</sup> and Guofei Jiang<sup>‡</sup>

<sup>†</sup>Department of Electrical and Computer Engineering, Drexel University, Philadelphia, PA 19104

<sup>‡</sup>Robust and Secure System Group, NEC Laboratories America, Princeton, NJ 08540

kusic@drexel.edu, kandasamy@ece.drexel.edu, gjf@nec-labs.com

**Abstract**—This paper develops a hierarchical control framework to solve performance management problems in distributed computing systems. To reduce the control overhead, concepts from approximation theory are used in the construction of the dynamical models that predict system behavior, and in the solution of the associated control equations themselves. Using a dynamic resource provisioning problem as a case study, we show that a computing system managed by the proposed control framework using approximation models realizes profit gains that are, in the best case, within 1% of a controller using an exact parametric model of the system.

## I. INTRODUCTION

This short paper describes an optimization framework to solve a class of performance management problems in distributed computing systems. We refer the interested reader to [1] for more details. The performance optimization problem is decomposed into a set of simpler sub-problems and solved in cooperative fashion by multiple controllers arranged in a decentralized hierarchical structure. Concepts from approximation theory are applied in two places—in the construction of the dynamical models to track and predict system behavior over a finite prediction horizon, and in the solution of the associated control equations.

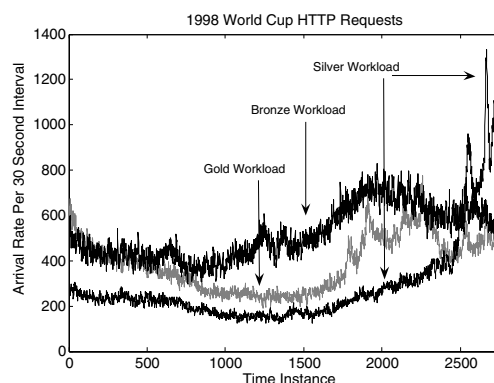

Fig. 2. An example workload representing client requests for the three online services hosted by the computing system

Simulations using workload traces from the 1998 World Cup Soccer web site (WC'98) show that a computing system managed by a control framework using approximation models realizes profit gains that are in the best case within 1% of a controller using a parametric model based upon first-principles while incurring low control overhead.

## II. SYSTEM MODEL

We assume a distributed computing environment (DCE) hosting three independent online services, labeled as “Gold”, “Silver”, and “Bronze” and indexed using  $i \in \{1, 2, 3\}$  as shown in Fig. 1. Requests for the Gold, Silver, and Bronze services arrive with time-varying rates  $\lambda_1(k)$ ,  $\lambda_2(k)$ , and  $\lambda_3(k)$ , respectively, and are routed to a computer cluster dedicated to hosting that service. Fig. 2 shows an example workload arrival pattern. Each cluster comprises heterogeneous computers with different processing capacities working independently to service incoming requests. Computers contributing excess capacity during periods of slow workload arrivals are powered down and placed in the Sleep cluster to reduce system power consumption. The Gold, Silver, and Bronze services generate revenue as per a pricing structure in which the response time of a completed request is translated into a dollar amount to be collected from the client. When the response time violates the SLA, the service provider pays a penalty to the client.

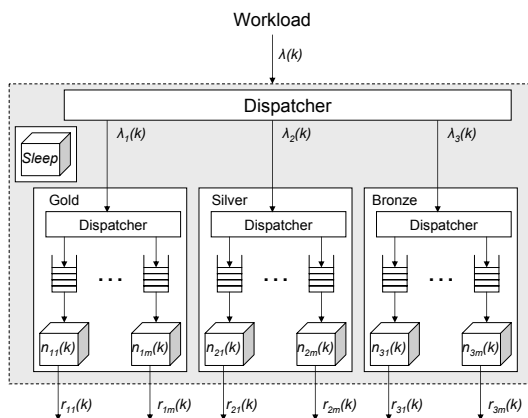

Fig. 1. The system model comprising the Gold, Silver and Bronze service clusters and a Sleep cluster holds machines in a powered-off state

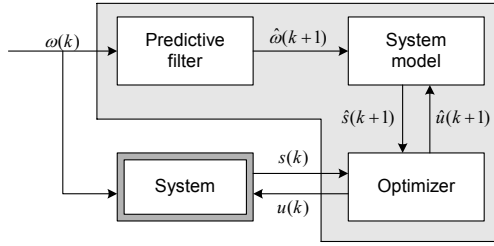
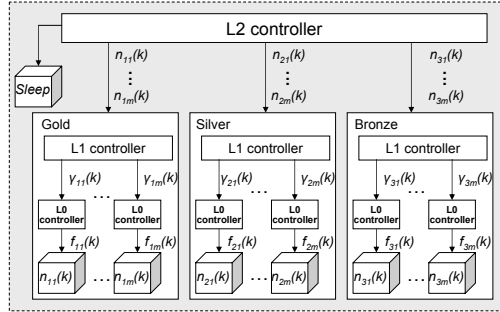

Fig. 3. The controller schematic

Fig. 4. The control hierarchy showing L2, L1 and L0 controllers superimposed upon the Gold, Silver and Bronze services and  $m$  performance classes within each service cluster

We approach the resource-provisioning problem using a limited-lookahead control (LLC) framework shown in Fig. 3—a predictive control approach allowing for multi-objective optimization and explicit constraint handling [2], [3]. The method applies to systems where control inputs must be chosen from a finite set within the discrete domain, and to systems with complex non-convex dynamics and dead times.

### III. CONTROLLER DESIGN

In the hierarchical control structure superimposed on the DCE in Fig. 4, a level 2 (or L2) controller with a global view of the system decides the number of computers  $n_{ij}(k)$  for the performance classes in each service cluster. One tier below, an L1 controller with a view of one service cluster decides  $\gamma_{ij}(k)$  to distribute the fractions of the incoming workload  $\lambda_i(k)$  among the performance classes. At the lowest level, an L0 controller local to each performance class decides the operating frequency  $f_{ij}(k)$  to assign to the servers.

This behavior of downstream components can be abstracted into inputs and outputs from a ‘black box’ view of the components, replacing the system model in Fig. 3 with an approximation. In an extension of the approximation structure, the behavior of the controller itself can be learned, replacing the iterative control process between the system model and optimizer in Fig. 3 with an approximation structure, reducing the control evaluation process to a single step.

### IV. SIMULATION RESULTS

Simulations using representative workloads show that a computing system controlled using the proposed LLC scheme with approximation structures achieves profit gains that are, in the best case, within 1% of those achieved with parametric

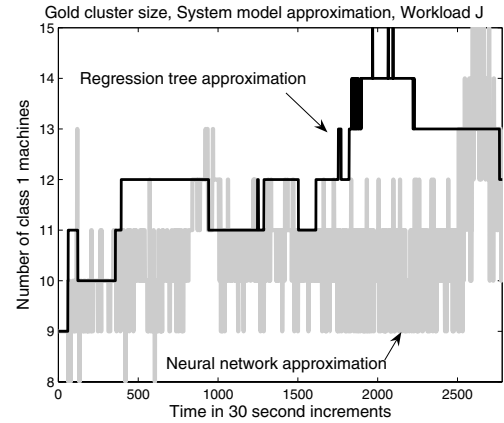

Fig. 5. Number of machines assigned to the Gold cluster by the L2 controller for workload J using an approximation in place of the system model

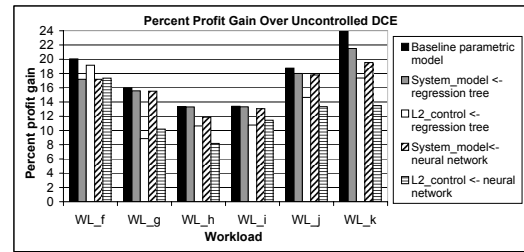

Fig. 6. A comparison of profit gains achieved by LLC managed DCEs over an uncontrolled system for six workloads similar that shown in Fig. 2

modeling using first-principles. The baseline for comparing the approximating LLC infrastructures is an LLC that uses a parametric model and has perfect knowledge of the system. Fig. 6 shows a comparison of the profit gains achieved by LLC managed DCEs over an uncontrolled system for six workloads similar to that shown in Fig. 2. All results are collected over a 24-hour period and generate more than the \$500 in profit earned by an uncontrolled system in a day.

Fig. 5 shows a comparison of the switching activity in the Gold cluster for machines by two LLC-managed systems, using a neural network and regression tree in place of a system model, respectively. For Workloads F, G, and J, the profit gains achieved by a controller in which the L2 level uses either approximation model are nearly the same, despite that Fig. 5 shows that the behavior of the L2 level controller varies greatly. Since controllers within the hierarchy cooperate to maximize the system utility, the impact of switching decisions made by the L2 controller are counteracted by the L1 and L0 controllers.

### REFERENCES

- [1] D. Kusic, N. Kandasamy, and G. Jiang, ‘‘Approximation modeling for the online performance management of distributed computing systems,’’ Drexel University, Tech. Rep., Feb. 2007.
- [2] D. Kusic and N. Kandasamy, ‘‘Risk-aware limited lookahead control for dynamic resource provisioning in enterprise computing systems,’’ in *Proc. of IEEE Intl. Conf. on Autonomic Computing (ICAC)*, June 2006.
- [3] S. Abdelwahed, N. Kandasamy, and S. Neema, ‘‘Online control for self-management in computing systems,’’ in *Proc. of Real-Time and Embedded Technology and Applications Symposium (RTAS)*, May 2004.