

Towards a Belief-theoretic Model for Collaborative Conceptual Model Development

Ebrahim Bagheri and Ali A. Ghorbani
Faculty of Computer Science, University of New Brunswick
Fredericton, NB, Canada
{e.bagheri,ghorbani}@unb.ca

Abstract

Merging and integrating different conceptual models which have been developed by domain experts and analysts with dissimilar perspectives on the same issue has been the subject of tremendous amount of research. In this paper, we focus on the fact that human analysts' opinions possess a degree of uncertainty which can be exploited while integrating such information. We propose an underlying modeling construct which is the basis for transforming conceptual models into a manipulatable format. Based on this construct, methods for negotiating over and merging of conceptual models are proposed. The approach presented in this paper focuses on the formalization of uncertainty and expert reliability through the employment of belief theory.

1 Introduction

Many researchers believe that requirement engineering is a process composed of two elements of requirement elicitation, and requirement modeling. In requirement elicitation, analysts are concerned with the revelation, communication, and validation of the facts related to the software entity, while in the modeling phase, they attempt to represent and organize the identified facts in some agreed format usually known as conceptual models. Conceptual models are therefore representational abstractions of the possible model of the software entity [1]. Conceptual modeling may be one of the most challenging aspects of the requirement engineering process.

As the magnitude and complexity of a software system increases, the development of its large conceptual model turns into a process that requires the collaborative effort of various viewpoints. A requirement engineering process with the involvement of various viewpoints is likely to wind up with many conflicting and inconsistent specifications. In the first glance these discrepancies may be considered unde-

sirable; however, their existence can point to the aspects of the system that deserve more attention and deeper analysis [12]. There have been several attempts to formalize the process of viewpoint-based requirement engineering and conceptual modeling, such as VORD [11], and CORE [4].

1.1 Contributions

There have been various proposals for the formalization of appropriate viewpoint-based frameworks. Each of these approaches have been devised with a specific motive and to address an important concern. For instance, Sabetzadeh and Easterbrook [9] propose the use of category theory and the colimit operator for merging viewpoints. They exploit Belnap's knowledge order [3] to define knowledge degrees which partially allows the identification of conflicts and uncertainty in the merged models. Similar to this work, Easterbrook and chechik [6] employ Quasi-boolean logics to reason over para-consistent specifications in the χ bel model and the χ chek model checker. The drawback of these models is that the inconsistencies are only identified and no further steps are taken afterwards. The proposed frameworks do not directly address the issue of resolving the identified conflicts and discrepancies. In another attempt, Ghose and Lin propose an incremental viewpoint merge strategy in which viewpoints' preferences are elicited, represented and ranked through the notion of epistemic states [7]. This model provides operators for finding and merging non-conflicting set of model descriptions. The disadvantage of this model is that each viewpoint should provide multiple models for a single problem.

The model that we introduce in this paper attempts to provide a basis for collaborative conceptual model development and integration, particularly with the existence of partial ignorance and uncertainty. The proposed work strives to capture experts uncertainty towards their expressed model specifications. Based on experts degree of ignorance and their detailed models, we propose a process through which the participating viewpoints can formally negotiate and

build common grounds. The outcome of this negotiation process would be a unified conceptual model for a given problem statement. Besides features for negotiation, the proposed model provides the viewpoints with effectiveness evaluation metrics that can help them understand the state of their negotiation. Furthermore, many authors have pointed out the fact that not all information sources are equally reliable. This is also true in conceptual modeling. Some analysts may be more dependable in their opinions in a specific concern as compared with the others; therefore, it is logical to consider the reliability of various experts while merging viewpoint information. Our proposed model discounts the expressed opinions of the experts with their degree of reliability before they are employed. The major advantages of our proposed model is that through the employment of viewpoint uncertainty and reliability information, formal negotiation processes can take place between the participants so that discrepancies can be identified and gradually removed.

1.2 The Overall Model

The integration model that we propose is founded on the degree of experts' uncertainty towards their expressed specifications. To capture the degree of uncertainty, we employ a three dimensional belief structure based on Subjective logic. This belief structure allows opinions to be expressed with varying degrees of belief, disbelief, and uncertainty. Furthermore, we propose an underlying language construct so that higher level conceptual modeling formalisms (e.g. UML, ERD, OWL, etc.) can be translated through it onto the belief layer. The exploitation of these two basic elements (the three dimensional belief model and the underlying modeling construct) allows us to reason about different specifications that are coming from multiple sources.

The viewpoint merging process is performed on the basis of belief merging operators such as Dempster's rule of combination. The only restriction that we apply on the expressed specifications is the use of a common application vocabulary. This is required so that specification overlaps are detected. We define various metrics for analyzing the effectiveness of the merging process and the quality of the obtained model. These metrics can assist the analysts in the process of decision making and planning. The merging process also develops and guides a formal negotiation process between the viewpoints so that a stable consensus is faster developed. Through the process of viewpoint merging and consensus building, the reliability of the experts and information sources are calculated with regards to various domains of expertise and will be used to discount the expressed information of the viewpoints.

It is important to notice that the merged views are not always syntactically or semantically consistent. Although

Lazy consistency allows the emergence of a richer final specification; however, it is required that the analysts perform a consistency check on the developed specification at some point of time. Our framework provides the basis for automatic syntactical correctness analysis of the specifications and allows the pruning of the specifications that are not significant from a collective perspective.

The overall flow of the proposed model can be seen in Figure 1. As it can be seen, each viewpoint initially expresses its own set of model specifications, and annotates them with proper belief values. These specifications are then automatically converted into belief structures using the underlying construct level definitions. By analyzing the belief structures, formal recommendations on belief adjustment are given to the viewpoints in order to guide them towards consensus. Once the viewpoints believe that they have reached an acceptable level of agreement, the specifications are merged and the reliability of the expressions of each viewpoint is computed. Simultaneously, integration effectiveness metrics are also calculated and provided to the viewpoints. The merge of the individual models causes inconsistencies that need to be resolved; therefore, this process is repeated until a stable merged model is obtained.

This paper is organized as follows: In the following section, a brief introduction to belief theory is given. Section 3 continues with the introduction of the theoretical developments of the framework, and is followed up by the elaboration of the model development and integration processes. Section 5 continues with the depiction of an example, and the paper is then concluded in Section 6.

2 Belief Theory

Many of the experts' judgements are mixed with uncertainty and imprecision. The explicit notion of uncertainty in experts' judgments requires proper requirement analysis models that benefit from viewpoint-based models that consider the role of uncertainty in their decisions; therefore, uncertainty and imprecision need also be captured through the process of elicitation in these models. Let's suppose that an expert intends to express his disagreement with a piece of information. This type of information can be expressed using traditional probability theory; however, this theory is not capable of representing and dealing with uncertainty. Traditional probability theory respects the principle of additivity, and therefore, the probability mass not assigned to a variable will be assigned to its complement, which is not applicable to the judgement of human experts. In human judgments, although a certain degree of agreement is assigned to a variable (P_i), it cannot be inferred that the expert believes in the complement of that variable with the rest of the probability mass not assigned to the variable ($1 - P_i$). It is possible that the rest of the probability mass be

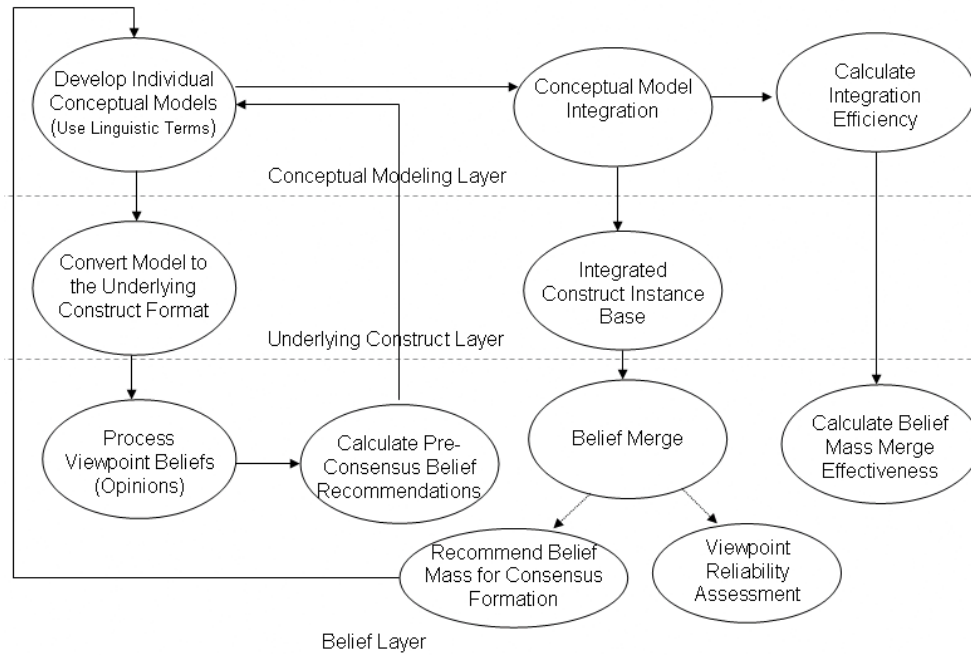

Figure 1. The Overall Flow of the Proposed Model

left unassigned and be interpreted as the degree of expert's ignorance or uncertainty.

Belief calculus is of the theoretical models which are able to numerically quantify the lack of expert's knowledge in an effective manner. It is a potentially useful tool for the evaluation of the reliability of experimental measurements of the factors that have been evaluated with the involvement of human experts. Dempster-Shafer theory of evidence is one of the most widely used models of belief representation that provides appropriate means for approximate and collective reasoning under uncertainty. It is an extension to the traditional probability theory where probabilities are assigned to sets (or intervals) as opposed to singleton variables [10].

The basis of the evidence theory is based on a set of hypotheses θ called the frame of discernment defined as:

$$\theta = \{H_1, H_2, \dots, H_N\}. \quad (1)$$

The frame of discernment consists of N exclusive hypotheses. Based on the frame of discernment θ , the power set 2^θ composed of all the possible propositions can be created such that:

$$2^\theta = \{\phi, \{H_1\}, \{H_2\}, \dots, \{H_N\}, \{H_1 \cup H_2\}, \dots, \theta\}. \quad (2)$$

The base function required for the evidence theory is the basic belief assignment (bba). It is similar to the probability

distribution, but differs in the fact that belief masses are distributed over the elements of the power set 2^θ and not only on the singleton elements of θ ; therefore, composite subsets of the power set can also receive a degree of the belief mass. The belief m_j assigned by an information source j is defined as a function that maps the power set to the $[0, 1]$ interval and should observe the following conditions:

$$m_j : 2^\theta \rightarrow [0, 1], \quad (3)$$

$$m_j(\phi) = 0, \quad (4)$$

$$\sum_{S \subseteq \theta} m_j(S) = 1. \quad (5)$$

The belief mass $m_j(S)$ shows how firmly the information source j believes in the hypothesis presented in S . In cases where S is a composite subset of θ , the belief mass assignment has been attributed to S due to uncertainty and the lack of information over the truthfulness of the subsets of S . We will later discuss that the finer the belief assignments are, the lower uncertainty will be. From the definition of the basic belief assignment function, two important functions can be defined: belief function, Bel_j , and the plausibility function, Pl_j . The belief function shows the amount of belief that information source j has assigned to any proposition such as S . The plausibility function represents the total amount of potential belief that can be assigned to a propo-

sition like S . The belief function is defined as:

$$Bel_j(S) = \sum_{B \subseteq S} m_j(B). \quad (6)$$

Dempster's rule of combination merges multiple belief functions expressed by various *independent* sources of information. The combination operator functions over two basic belief assignments m_1 and m_2 . The result is a compilation of the collective belief of the two information sources ($m_{1,2}$).

$$m_{1,2}(S) = \frac{\sum_{A \cap B = S} m_1(A)m_2(B)}{1 - K}; S \neq \phi, \quad (7)$$

$$K = \sum_{A \cap B = \phi} m_1(A)m_2(B). \quad (8)$$

K is a normalization factor that represents the degree of conflict between the expressed belief of the information sources. Dempster's rule redistributes the conflicting masses over the non-conflicting masses and therefore insists on the mutual agreements and removes conflicts. This approach to belief integration has been criticized due to its counter-intuitive results under highly conflicting belief expressions. Several authors have proposed models to overcome this problem. For instance, Smets has proposed the assignment of the conflicting masses to ϕ . His interpretation of conflicts is that they occur when the hypothesis space is not exhaustive. In a different approach, Yager proposes the assignment of conflict masses to θ , and interprets it as the degree of overall ignorance. We will employ Yager's interpretation in the process of evaluating information sources' reliability.

3 Formal Basis

In this section, we will discuss the theoretical basis of our approach. The belief foundation for expert opinion expression will be formalized and proper methods for converting opinion expressions from linguistic terms into belief structures and vice versa will be discussed. An underlying modeling construct will also be developed and the possibility of converting conceptual models developed based on UML into the proposed belief format will be investigated. The process of modeling experts' reliability from the perspective of various domains of concern will also be formalized.

3.1 Opinion Foundation

In the process of modeling with the involvement of various experts, each piece of gathered information can be represented in the form of a declarative expression. As an example, consider a case in the design of an electronic

learning system where one of the analysts (A_i) has defined the concept of 'course' as a UML class. This can be expressed as '*belief*($A_i, class(course)$)'; which means that expert A_i believes that a course should be modeled as a class in the conceptual model. Based on this model, since the analyst does not have any doubt (uncertainty) about the expressed specification, he/she is completely certain that he/she does not believe in modeling a course as an attribute of a larger class. Let's suppose that expert A_i 's belief about the course concept being modeled as a class be x , then we have: *belief*(x) = 1, *disbelief*(x) = 0 and *belief*(\bar{x}) = 0, *disbelief*(\bar{x}) = 1.

It can be seen from the example that the set of hypotheses only consists of x and its complement (\bar{x}); therefore, the frame of discernment is binary, which means that there are only two hypotheses here that can receive belief masses in the framework of belief calculus. It is logical to employ Subjective logic an extension of the Dempster-Shafer theory of evidence that supports belief representation and reasoning in binary frames of discernment. Subjective logic explicitly defines uncertainty as a separate dimension which is actually implicit in the definition of belief in the Dempster-Shafer theory. This is a major advantage for our purpose since we intend to capture experts' uncertainty about their expressions.

A belief expression in Subjective logic is defined as a 3-tuple $\omega_x^A = (b_x^A, d_x^A, u_x^A)$, also known as the opinion of expert A about hypothesis x . It can be shown with this definition that belief, disbelief, and uncertainty elements of an opinion should satisfy: $b_x^A + d_x^A + u_x^A = 1$.

The above equation restricts the possible values that can be expressed as an opinion by an expert only to the points placed in the interior surface of an equal-sided triangle. The three constituent elements determine the position of an opinion within the triangular space. In the opinion triangle, the line connecting absolute belief and absolute disbelief corners (right and left corners) is called the probability axis. This is because the removal of uncertainty from Subjective logic will result in a pure probabilistic interpretation of belief (i.e. $b_x^A + d_x^A = 1$).

3.1.1 Linguistic Opinions

Domain experts and analysts are generally uncomfortable with expressing their opinions in an exact probabilistic form. They prefer to use common linguistic terms to articulate their opinions in a rough manner. For this reason, it is required to convert linguistic expressions of the experts into a mathematical format so that calculations can be performed and then re-convert the mathematical values into linguistic terms for expert comprehension.

In the belief triangle, the uncertainty axis and the probability axis can be divided into four and five sections, respec-

tively. Each of these divisions represent a linguistic term. For example, partitions on the uncertainty axis can develop the absolutely uncertain, very uncertain, slightly certain, and absolutely certain terms that can be used by the experts. On the other hand, certain divisions on the probability axis can create five linguistic terms, namely firm disagreement, slight disagreement, either way, slight agreement, and firm agreement. If we consider the spaces that are created by the intersection of these two divisions, we will have various sub-spaces within the triangle that roughly represent certain linguistic expressions.

Once an opinion has been expressed in a linguistic form, it can be converted into its mathematical representation by first finding its correct location in the triangle, and then taking the value of the belief elements of the center of gravity of the corresponding sub-space as the representative of the expressed opinion.

3.2 The Core Representation Model

The integration of conceptual models is the issue of many different application domains such as requirement engineering, database schema development, and ontology creation to name a few. For this reason, it would be enticing to create an integration model which is independent of the actual conceptual modeling formalism that has been used to create the specifications. To achieve this, a lower level modeling construct is required so that the higher level conceptual models can be mapped through it and the reasoning process be performed based on the lower level belief structures. The results of the operation on the lower level models can then be mapped back to the higher level conceptual models.

Construct is a low level modeling notion that we propose for processing higher level models. It has the capability to be decorated with belief elements that can be used for reasoning and integration. Construct has four segments: Attributes, Opinion, Pre-condition, and Post-condition. Attributes are the set of elements that are needed in the higher level model. Construct has three default attributes that can be extended by analysts. These attributes are Name, Cardinality, and Contributors. The name attribute allows each construct to have a unique name, cardinality defines the number of identical instances that are permissible, and the contributors attribute is used to identify the list of experts (viewpoints) that have affected the definition of this instance of the construct used for traceability purposes.

The belief segment consists of three elements namely belief, disbelief, and uncertainty that are employed to assign subjective opinions to each instance of the construct. Pre-conditions and post-conditions are the set of circumstances that need to hold before and after the creation of an instance of a specific construct. Suppose that a group of analysts

each representing a different viewpoint have agreed upon using the class diagrams of the unified modeling language as the high level conceptual modeling language. In order for them to be able to use our proposed integration model, the underlying construct model should be customized for the class diagram of the unified modeling language. Here, we show how the class, notion from the set of all concepts in the class diagrams can be defined in the construct format. The definition of the rest of the concepts in the unified modeling language, entity-relationship model, OWL, etc., trivially follow the same path and are very similar to what is shown in the following.

```

Construct Class (instanceName)
Attributes
    name= instanceName
    Cardinality=1
    Contributors=*
Opinion
    belief=1
    disbelief=0
    uncertainty=0
Pre-condition
    belief(X, this.name)<disbelief(X, this.name)
    + uncertainty(X, this.name)
Post-condition
    if (belief(Class, this.name)>0.5) {
        disbelief(X-{Class}, this.name)=belief(Class, this.name)
        uncertainty(X-{Class}, this.name)=disbelief(Class, this.name)
        +uncertainty(Class, this.name)
        belief(X-{Class}, this.name)=0
    }
End Construct
    
```

As it can be seen in the definition, the name of each instance is to be assigned by the analyst, and only one instance of each concept with the same specification is permitted. Opinions are set to complete belief by default that will be over-ridden by the belief values that are provided by the analysts. If no belief value is assigned to the concepts, a full degree of belief is assigned to it; therefore, in cases where the modelers feel that assigning belief values are a big burden they can ignore it and a full belief value will be assigned automatically.

The most important section of the definitions are the pre and post-conditions. In the Class construct, it should be made sure that if a different construct instance has been created with the same name, the belief of the analyst is lower than the sum of the uncertainty and the disbelief for that instance. This pre-condition makes sure that there exists a certain degree of belief that can be assigned to this construct. In the definitions above, *X* is a variable that can be unified with any defined construct.

Post-conditions are propositions that should hold having

expressed an instance of the construct. For example, the post-conditions for the Class construct are that if the belief value assigned to an instance construct is higher than 0.5, all other constructs instances with a similar signature other than the Class construct should be assigned the complement of the belief value assigned to this instance of the construct. This condition does not apply to constructs with a belief lower than 0.5, since a person may disagree with multiple construct instances which does not mean that he/she agrees with the other constructs and therefore the other constructs should not receive the complement of the belief. To clarify this point, consider a case where an analyst has stated that a given concept should not be modeled as a Class. This statement does not mean that he/she agrees with the proposition that the concept should be modeled as a property. However on the contrary, if the analyst states that a given concept should be modeled as a class, it can be inferred that he does not believe in it being modeled as a property. It is important to observe the condition that only construct instances that do not possess a prior directly assigned belief value can be automatically assigned a degree of belief.

3.3 Expert Reliability Analysis

In our perception of viewpoint-based specification, concerns are one of the most important aspects of the model. The definition of concern in our model is similar to what has been defined in [11]. Based on this definition, each viewpoint may be responsible for considering the information regarding several specific concerns of the system. Since not all analysts have the same degree of expertise in all of the different concerns that are considered in the elicitation process, a reliability metric needs to be defined. This reliability metric can be used to discount the information which is expressed by that viewpoint. According to the fact that we employ concerns (n concerns), each viewpoint can be assigned a set of different reliability measures (one for each concern).

The set of reliability values attributed to each viewpoint have two faces. Firstly, the analysts involved in the creation of the specifications for each viewpoint are asked to express their degree of confidence in their understanding and knowledge of that area of concern. Secondly, a third-party understanding of the reliability of each viewpoint in a specific concern is taken into consideration. The third-party reliability values can be set equally for all viewpoints if no extra information about the viewpoints are available. We will explain how third-party reliability beliefs are calculated later in this paper.

Viewpoint analysts are initially asked for the perception of their own reliability. They can state their opinion from within the range of $[0, 1]$. It is rather intriguing to interpret the reliability values assigned to each viewpoint as the

amount of belief mass that has been assigned to each viewpoint. The ascribed mass (assigned either by the viewpoint itself or the third-party) represents the degree of belief in the fact that the viewpoint is going to reveal the correct specification; therefore, the combination of the two reliability values reduces to the problem of combining two belief mass assignments. We propose the use of Yager's rule of combination which is actually the application of Dempster's rule of combination without normalization. Yager's rule can be considered as an epistemologically honest interpretation of the belief masses since it does not change the value of the belief masses through normalization. Instead of normalization, Yager's rule assigns the conflicting belief mass to the universal set θ .

4 The Merge Procedure

The provided information by each viewpoint should be in the form of an agreed conceptual model. These models need to be consolidated into one single model that correctly represents the perspective of all the viewpoints. In this section, we will describe how various conceptual models originating from different viewpoints can be merged on the basis of negotiation, consensus building, and model pruning.

4.1 Model Integration

Conceptual models need to be mapped onto the belief layer using the underlying construct layer before they can be merged. As was explained in the previous sections, the conversion process can be performed automatically based on the defined pre and post-conditions of the related constructs. Upon conversion of the conceptual models, merging can take place. There have been various proposals for combining belief masses among which we choose the consensus operator [8] to merge various conceptual models. The choice of the consensus operator has been due to three facts. Firstly, the consensus operator has been designed specifically for binary frames of discernment which are the types of frames that we have also chosen for our model. Secondly, the operator has been shown to have a stable behavior under various conditions and even while merging conflicting dogmatic beliefs [8]. Finally, it is an appealing choice since it satisfies two important algebraic properties i.e. commutativity ($A \oplus B = B \oplus A$), and associativity ($A \oplus [B \oplus C] = [A \oplus B] \oplus C$). These two properties are of great significance since the merging process of conceptual models should neither be affected by the order used for the merge process nor the order of models while being manipulated by the merging operator.

Let $\omega_x^A = (b_x^A, d_x^A, u_x^A)$ and $\omega_x^B = (b_x^B, d_x^B, u_x^B)$ be two opinions about a common fact x stated by two different parties A and B , and let $\kappa = u_x^A + u_x^B - u_x^A u_x^B$.

When u_x^B , and $u_x^A \rightarrow 0$, the relative dogmatism between the two opinions are defined using $\gamma = u_x^B/u_x^A$. Now let $\omega_x^{A,B} = (b_x^{A,B}, d_x^{A,B}, u_x^{A,B})$ be a fair representative of both opinions such that:

when $\kappa \neq 0$	when $\kappa = 0$
$b_x^{A,B} = (b_x^A u_x^B + b_x^B u_x^A)/\kappa$	$b_x^{A,B} = \frac{\gamma b_x^A + b_x^B}{\gamma + 1}$
$d_x^{A,B} = (d_x^A u_x^B + d_x^B u_x^A)/\kappa$	$d_x^{A,B} = \frac{\gamma d_x^A + d_x^B}{\gamma + 1}$
$u_x^{A,B} = (u_x^A u_x^B)/\kappa$	$u_x^{A,B} = 0$

$\omega_x^{A,B}$ is the opinion resulting from the application of the consensus operator on two opinions from different sources about a common hypothesis. The employment of the consensus operator can provide a basis for merging conceptual models that are in essence uncertain. We employ the consensus operator along with a widely used model called discount and combine (aka the tradeoff model) [10]. This model discounts the information provided by each viewpoint related to a certain concern with the reliability values of that viewpoint in that specific concern. The employed discounting operator [8] is defined as:

$$b_{x \rightarrow c_i}^{A:R_A^{C_i}} = b_{x \rightarrow c_i}^A b_{R_A^{C_i}} \quad (9)$$

$$d_{x \rightarrow c_i}^{A:R_A^{C_i}} = b_{x \rightarrow c_i}^A d_{R_A^{C_i}} \quad (10)$$

$$u_{x \rightarrow c_i}^{A:R_A^{C_i}} = d_{x \rightarrow c_i}^A + u_{x \rightarrow c_i}^A + b_{x \rightarrow c_i}^A u_{R_A^{C_i}} \quad (11)$$

where $b_{x \rightarrow c_i}^{A:R_A^{C_i}}$ is the belief of viewpoint A about a hypothesis x related to *Concern* i discounted with the viewpoint's reliability in that specific concern ($R_A^{C_i}$). The rest of the notations can be interpreted similarly.

4.2 Consensus Effectiveness

The process of belief revision and combination in conceptual model integration is repeated iteratively until a desirable degree of stability is reached. Measuring the degree of stability requires some quantitative measure for evaluating the combined model. Stephanou and Lu have proposed a quantitative metric called the generalized entropy criterion which measures the degree of consensus effectiveness obtained as a result of combining evidences from multiple sources through the application of the Dempster's rule of combination [13].

It has been shown that the generalized entropy criterion decreases with consensus; therefore, the amount by which it decreases as a result of consensus can be considered as the degree of consensus effectiveness. There are various obstacles to the direct application of the generalized entropy criterion in our application domain. Firstly, it seems that

the generalized entropy criterion is most suitable for large frames of discernment, and hence some of its metrics such as partial ignorance do not make sense in a binary frame with singleton elements. Furthermore, Since the entropy model is designed for measuring consensus effectiveness based on Dempster's rule of combination, it has assumed that the conflict mass has been normalized out in combination, which is not a correct assumption in our case. It also does not directly address uncertainty and disbelief dimensions that are present in our belief formalization. For these reasons and inspired by the generalized entropy criteria, we propose three similar metrics for measuring consensus effectiveness, namely ambiguity (ζ), undecisiveness (ψ), and conflict (δ).

Each of the metrics are calculated separately for all of the present concerns in the analysis process. The metric values for each concern are superscripted with the corresponding concern indicator. For instance, ζ^k depicts the ambiguity value with regards to concern k . Ambiguity is defined as:

$$\zeta^k = - \sum_{i=1..n_k} \left(\frac{1}{e^{1-(b_{x_i^k} + d_{x_i^k})}} - 1 \right). \quad (12)$$

Ambiguity is similar to belief entropy in that it provides the basis to calculate the degree of confusion in the overall viewpoints knowledge about the exact fraction of belief that they should assign to each hypothesis. The undecisiveness metric is a measure of the ability of the viewpoints to firmly state a given proposition. For this purpose, the further away the degree of belief and disbelief of a given hypothesis are, the stronger and more decisive the hypothesis is:

$$\psi^k = \sum_{i=1..n_k} \left(\frac{2}{e^{(b_{x_i^k} - d_{x_i^k})} + e^{(d_{x_i^k} - b_{x_i^k})}} - \frac{2e}{e^2 + 1} \right). \quad (13)$$

The third metric that we define for consensus stability analysis is the conflict metric. Conflict defines the degree of inconsistency between the beliefs of the different viewpoints. Therefore, analogous to the previous two metrics, conflict should also be minimized for reaching a more stable conceptual model as a result of consensus.

$$\delta^k = \sum_{j=1..n_k} (b_j d_j^{consensus} + d_j b_j^{consensus})/2. \quad (14)$$

where n_k is the number of propositions in viewpoint k . To create a unified view for each of the three metrics, the value of the metrics in each concern should be aggregated. The aggregation process is a weighted sum of each metric. The applied weight is proportional to the number of propositions in the corresponding concern. As mentioned earlier, the process of belief revision and integration is repeated until a stable and agreeable model is reached.

4.3 Third-party Reliability

The third-party reliability beliefs assigned to each viewpoint is based on that viewpoint's activities within each concern. To identify the degree of change that must be applied to the reliability belief of a given viewpoint, three metrics need to be calculated which are derived from the factors introduced in the previous section, namely average conflict, ambiguity change, and undecisiveness change. Average conflict is measured by integrating the belief propositions of a viewpoint with the consensus belief base developed in the previous cycle. Based on the integration, the average degree of conflict between the expressed opinions of the viewpoint and that of the consensus belief base is measured. Ambiguity change is determined similarly to average conflict, but instead of calculating the average conflict, the degree of change in the ambiguity factor of the consensus belief base is measured. Analogous to the other two metrics, undecisiveness change computes the degree of change in the undecisiveness factor of the consensus belief base. It should be noted that the lower these three metrics are, the more effective and successful the viewpoint has been in that certain concern.

The three evaluated metrics are each split into three segments, namely effective (+), neutral (°), and ineffective (-). The average (\bar{f}_j) and standard deviation ($std(f_j)$) of each metric (f_j) is calculated over all of the viewpoints. The viewpoints that have at least two of their metrics within $[\bar{f}_j - std(f_j), \bar{f}_j + std(f_j)]$ are considered as neutral. Subsequently, the viewpoints with at least two metrics located in $(-\infty, \bar{f}_j - std(f_j))$, or $(\bar{f}_j + std(f_j), +\infty)$ are considered to be effective or ineffective, respectively. According to this classification, the reliability of the viewpoints that are located in the effective zone is increased by a specific amount (ϵ). To keep the balance of the reliability beliefs, the same amount of belief is reduced from the ineffective viewpoints. In cases where there are no ineffective viewpoints, the belief mass assigned to the effective viewpoints is reduced from the neutral viewpoints. Let n be the number of viewpoints in the effective zone and m be the number of beliefs in either the ineffective or neutral zones, and α be a moratorium factor which defines the degree of applied penalty, ϵ is defined as:

$$\epsilon = \frac{\sum_{i=1}^m \mathfrak{R}_i^{C_j} \times \alpha}{n}. \quad (15)$$

where $\mathfrak{R}_{V P_i}^{C_j}$ is the third-party reliability belief ascribed to viewpoint i for concern j .

4.4 Finalizing Model Integration

The integration of various conceptual models can result in inconsistencies that may have not been present in the ini-

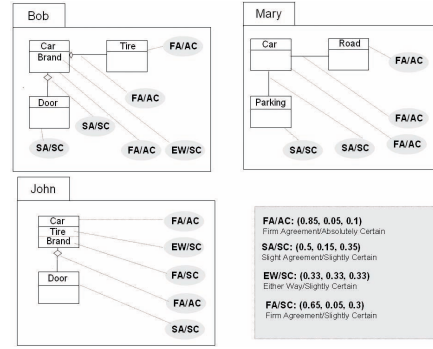

Figure 2. Three Viewpoints Have Expressed Their Opinion About a Single Model.

tial conceptual models. It is recommended that these inconsistencies be tolerated until the situation under which a final decision must be made on the ultimate conceptual model. This means that inconsistencies, and conflicts should be resolved at some point in time; however, consistency enforcement is usually one of the last activities that are performed in the model integration process.

In the model that we have proposed in this paper, inconsistencies and conflicts arise as a result of the difference in the belief mass assigned to different hypotheses by various viewpoints. The conflict may be resolved through the consensus building process. Briefly, the employed consensus building process is a recommendation scheme which is defined as follows. Let \otimes and \oplus be the discount and consensus operators, and B^{Rec} , $B^{V P_i}$, and B^{Con} be the recommended belief base, viewpoint i 's belief base, and the consensus belief base, respectively. The recommendation process can be expressed as:

$$B^{Rec} = [\otimes (\mathfrak{R}_{V P_i}^{C_j}, B^{V P_i})] \oplus [\otimes (\mathfrak{R}_{Con}^{C_j}, B^{Con})]. \quad (16)$$

The recommendations are made to all viewpoints so that consensus is formed more easily and quicker. In cases where conflict still exists, a decision must be made as to which proposition to select from amongst the conflicting opinions. Here, it is possible to select the proposition with the highest degree of potency. Potency of each proposition is defined as:

$$Potency_x = \begin{cases} 0 & \text{if } u_x = 1 \\ \frac{b_x - d_x}{1 - u_x} & \text{else} \end{cases} \quad (17)$$

The inconsistent propositions are ordered based on their degree of potency, and the proposition with the highest degree of potency is selected as the appropriate one, and the rest are removed. In cases where several propositions have the same degree of potency, the one with the higher value of belief, and lower uncertainty is selected.

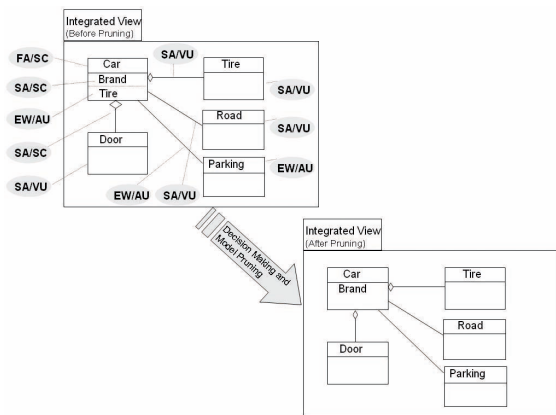

Figure 3. The Conceptual Models Are Initially Merged and then Pruned and Finalized.

5 An Example

Let us now consider an example where three analysts John, Bob, and Mary representing three different viewpoints collaborate to create a complete model of a transportation system. We partially show how these viewpoints can collaborate to create a unified conceptual model. For simplicity purposes, the analysts consider the system from a single shared perspective (single concern) and we further assume that the analysts are equally reliable which means that each of them is assigned a (0.33, 0, 0.66) reliability belief. Figure 2 shows a part of the conceptual models designed by each of the perspectives (The letters in the gray ovals represent viewpoint opinions in linguistic terms). As it can be seen the models are annotated with opinion values that help the integration process.

In this example, Bob and John are concerned with the design of the car itself, while Mary is aiming to design the external relationships of the car with the other elements. Before the integration of the models, we have to transform them into the underlying construct. While transforming the conceptual models into the underlying construct, we can infer that there is an inconsistency between the models designed by Bob and John which is the result of the difference in the definitions of the concept of tire. John has modeled the tires of a car as its attributes, while Bob has defined them as a separate stand-alone class.

After the models have been turned into the belief model using construct representation they can be merged by first discounting each of the propositions of the models with the reliability of the viewpoint and then combining them using the consensus operator. The models are not yet checked for inconsistency, and hence the existence of conflict is permitted. As it can be seen in Figure 3, the merged model con-

tains partial inconsistency that needs to be resolved. Based on the potency metric, we can infer that the model that has defined the tire of a car as a stand-alone class has a higher degree of believability and therefore, the notion that has modeled tire as a class attribute is removed from the final conceptual model.

It is worth noting that each of the viewpoints had the possibility to insist on its opinion by explicitly adding the conflicting proposition stated by the other viewpoints to their belief base and assigning it a very high degree of disbelief. For example, John could have added a tire class to its model and assigned it an ‘Absolutely Certain/Firm Disagreement’ opinion. This would have significantly affected the final merged model. On the contrary, Since he/she had already expressed some doubt on his/her first proposition by assigning an ‘Either Way/Slightly Certain’ opinion to the tire attribute, he/she could have overly softened his/her opinion (or even removed his/her initial proposition) so that consensus could have been achieved more easily and the degree of confidence in the final product would have been higher.

6 Concluding Remarks

In Section 1.1, we elaborated on the issues that are to our high interest and need to be addressed in the proposed model. Here, we re-visit those points and discuss the contributions of our proposed model. First, based on the understanding that conceptual modeling is a process that is widely used in different domains, the opportunity for crafting a syntax independent model was found to be precious. A low-level construct that allowed high-level modeling language concepts to be mapped through it onto appropriate belief structures was therefore devised in the proposed model. Using this underlying construct, various conceptual modeling languages can be exploited for the modeling purpose, which can be mapped and employed by the reasoning and consensus tools that are available for that model. Since conceptual models can be converted through the construct model; the analysts need not be familiar with the syntax of the underlying construct.

Modeling the uncertainty of the domain experts and analysts and their ignorance towards the absolute correct conceptual model is to our belief a major issue, which was explicitly addressed through the use of belief theory and Subjective logic in the proposed model. This basis provides suitable means for integrating models in the presence of uncertainty, and even discrepancies. The integrated models can be further refined by a semi-automated negotiation and consensus building model proposed in this paper which is based on recommendations for belief revision to the viewpoints. The interactions between the proposed model and the viewpoints are all in the form of linguistic terms so that no extra conceptual burden is put on the analysts and mod-

elers.

It can be shown that the proposed model introduced in this paper, is a generalization of the model proposed by Sabetzadeh and Easterbrook [9]. In their model, the authors employ Belnap's knowledge order to annotate viewpoint elements. The variant that they have used in their paper consists of four values: ! which means that the element has only been proposed, \checkmark shows that the element is affirmed, % is assigned to an element which is repudiated, and finally $\frac{!}{\checkmark}$ is used to specify the elements that are disputed. Based on these values and with the help of the least upper bound operator, the result of the integration of several annotated elements can be computed. For instance, the result of the integration of three elements with !, \checkmark , and % as their annotation values will be an element classified as disputed ($\frac{!}{\checkmark}$). This case is similar to a case where the analysts in our proposed model do not provide any explicit opinion about the propositions that they express. In this case, extreme opinions are assigned to the statements (total belief, or total disbelief). The application of the consensus operator on these elements has a similar result as what has been proposed in [9] and hence reduces to the least upper bound operator under boundary conditions. Even though in such a case the two models show similar behavior for integration, our model provides the analysts with proper tools to determine the degree of integration (consensus) effectiveness. These measures can be employed as indicators to show if further negotiation is needed between the viewpoints.

Easterbrook [5] describes three strategies for conflict resolution namely, cooperative, competitive, and the third party method. In our proposed framework, the viewpoints can benefit from all three of these strategies. The recommender scheme develops a cooperative platform for gradually resolving conflicts and removing discrepancies. On the other hand, each viewpoint can insist on its own design by ignoring the recommendations or explicitly expressing its disagreement with the other viewpoints design which is actually a competitive strategy. Ultimately, if the employment of these two models of conflict resolution does not yield an acceptable result, the potency metric is used to prune inconsistent and conflicting propositions. The potency metric can be considered as a third party resolution strategy which is indirectly based on belief structures and viewpoint reliability. The other important aspect of the proposed model is the consideration of viewpoint reliability in the model integration process.

Finally, One of the significant issues that needs to be considered is the extra burden that the proposed model imposes on the viewpoints by requiring them to annotate their conceptual model elements. It should be noted here that the viewpoints are not obliged to fully annotate their conceptual model; therefore, if the propositions are not annotated, total belief will be automatically assigned to the given proposi-

tion. In such a case the process is still meaningful. Even more, the viewpoints are even free to only annotate a subset of their conceptual model that they think is required (or that may need more detailed negotiation.) In this way only very little extra work is needed from the participating viewpoints.

We are currently testing the performance of the proposed model through several case studies with the help of different analysts. We are evaluating the correctness of the final conceptual models developed through the help of this framework using the precision and recall metrics. We are also interested to study the efficiency of the recommender scheme. Initial results show that the proposed model has a reasonable behavior. Some preliminary results have been reported in [2]. The proposed model is currently supported by a set of plug-ins developed for the Eclipse framework, namely Integration Client, and Integration Server. The plug-ins are developed on top of the Eclipse Modeling Framework (EMF). The viewpoints can install the integration client plug-in into Eclipse and develop their conceptual models. As future work, we are interested in developing schemes that address both pre and post-integration belief recommendation for the viewpoints so that consensus formation and negotiation among the viewpoints is enhanced.

References

- [1] J. Andrade, J. Ares, R. Garcia, J. Pazos, S. Rodriguez, and A. Silva, *A methodological framework for viewpoint-oriented conceptual modeling*, IEEE Transactions on Software Engineering **30** (2004), no. 5, 282–294.
- [2] Ebrahim Bagheri and Ali A. Ghorbani, *A framework for distributed collaborative conceptual model development*, OOPSLA Companion, 2007.
- [3] Nuel D. Belnap, *A useful four-valued logic*, Modern Uses of Multiple-Valued Logics (J. Michael Dunn and George Epstein, eds.), Reidel, Dordrecht, 1977, pp. 8–37.
- [4] Peta Darke and Graeme Shanks, *Stakeholder viewpoints in requirements definition: A framework for understanding viewpoint development approaches*, Requirements Engineering **1** (1996), no. 2, 88–105.
- [5] Steve Easterbrook, *Resolving requirements conflicts with computer-supported negotiation*, Requirements engineering: social and technical issues (San Diego, CA, USA), Academic Press Professional, Inc., 1994, pp. 41–65.
- [6] Steve M. Easterbrook and Marsha Chechik, *A framework for multi-valued reasoning over inconsistent viewpoints.*, ICSE, 2001, pp. 411–420.
- [7] Aditya Ghose and Qiuming Lin, *Viewpoints merging via incrementally elicited ranked structures.*, QSIC, 2006, pp. 141–150.
- [8] Audun Josang, *A logic for uncertain probabilities*, Int. J. Uncertain. Fuzziness Knowl.-Based Syst. **9** (2001), no. 3, 279–311.
- [9] Mehrdad Sabetzadeh and Steve Easterbrook, *View merging in the presence of incompleteness and inconsistency*, Requir. Eng. **11** (2006), no. 3, 174–193.
- [10] K. Sentz and S. Ferson, *Combination of evidence in dempster-shafer theory*, Tech. report, Sandia National Laboratories, SAND 2002-0835, 2002.
- [11] Ian Sommerville and Pete Sawyer, *Viewpoints: principles, problems and a practical approach to requirements engineering*, Annals of Software Engineering **3** (1997), no. 0, 101–130.
- [12] G. Spanoudakis and A. Zisman, *Inconsistency management in software engineering: Survey and open research issues*, Handbook of Software Eng. and Knowledge Eng. **1** (2001).
- [13] Harry E. Stephanou and Shin-Yee Lu, *Measuring consensus effectiveness by a generalized entropy criterion*, IEEE Trans. Pattern Anal. Mach. Intell. **10** (1988), no. 4, 544–554.