

# Market Structure and the Predictability of Electricity System Line Flows: An Experimental Analysis

Nodir Adilov, Thomas Light, Richard Schuler, William Schulze, David Toomey, & Ray Zimmerman  
Cornell University, Ithaca, NY 14853  
res1@conell.edu

## Abstract

Robert Thomas [3] has shown, using simulations of experimental results, that the power flow on any line in an electric network is linearly proportional to the total system load when that system is optimally dispatched using accurate generator cost data. By comparison, when offers from generators obtained in a wholesale market that is not perfectly competitive are used to dispatch the system, that relationship between line flow and system load becomes nearly random. These simulations were conducted in a single-sided market environment, however, that is typical of most wholesale market regimes around the world. Here the central dispatcher (ISO, RTO, etc.) accumulates the demand from various buyers and satisfies that load with a least-cost purchase schedule, regardless of price, subject to all of the physical and reliability constraints imposed on the system. If buyers were also able to submit a schedule of bids that are related to price, does the same random relationship between line-flows and system load prevail?

This experimental analysis demonstrates that letting the customers participate fully in the market re-establishes the predictability of line flows as a function of system load. In all of these experiments there are no restrictions on permissible offering behavior by suppliers (e.g. no price caps, prohibitions on withholding capacity or automated mitigation procedures). Two alternative forms of demand side participation are considered: 1) a demand response program (DRP) where customers are alerted to high prices in the subsequent period and are paid a pre-specified amount for each kWh less than their benchmark level of usage for that period, and 2) a real time pricing program (RTP) where customers are given forecasts of prices for each period over the subsequent day and they then pay the actual period-by-period market clearing price. As a benchmark, these experiments with six suppliers and seventeen buyers are also repeated where customers pay an average constant price in all periods (FP); although in all cases sellers receive the market-clearing price in each period.

R-squares were greater, variances were smaller and the t-tests on regression coefficients were stronger on the relationship between line-flow and system load for RTP, as compared to the FP system that is commonly used in most electricity markets. DRP was usually somewhere in

between. Not only does inducing active customer participation in the market through RTP lead to better system predictability, it also reduces price spikes and leads to greater overall economic efficiency in these markets. It is a winner on both economic and operational grounds.

## 1. Introduction

In previous experimental analyses of typical single-sided electricity markets, the resulting simulated line flows are linearly proportional to system load when the dispatch that minimizes total system cost is based upon the actual cost of generation (e.g. perfectly regulated or perfectly competitive markets). But when that least-cost dispatch is based upon offers where the suppliers can speculate, that physical relationship breaks down and is highly erratic (See Thomas [3]). Thus it is interesting to explore these simulated physical line flows in a set of recent experiments on full two-sided markets with active demand-side participation. While a primary concern in electricity markets has been to reduce price spikes and to improve competitiveness and overall economic efficiency, it is important to understand how variations in market design that are intended to achieve those economic goals also affect the physical characteristics of the system.

A recent set of experiments was designed to test the efficiency of two alternative forms of active demand-side participation in full two-sided electricity markets (See Adilov, et.al. [1]). As a base case for comparison, the typical utility pricing mechanism where buyers pay a pre-determined fixed, constant price (FP) in all periods was also tested. Here buyers merely determine how much electricity they wish to purchase in each period. In the second treatment, buyers are alerted prior to consumption periods when supply shortages are anticipated. In those periods, customers are given the opportunity of reducing their consumption below their normal benchmark purchases in similar periods, and by doing so they can earn a pre-specified credit per kWh for each unit of electricity less than their benchmark that they choose to buy. This treatment is analogous to the NYISO's Emergency Demand Response (DRP) program. All electricity actually purchased under this DRP scheme is priced at the same fixed price used in the base case, but

total customer payments are reduced by any DRP credits earned. The third treatment is a simple real time pricing (RTP) scheme; wherein, price forecasts are announced for the next day and night periods, and based upon these forecasts, buyers decide how much electricity to purchase. However, buyers must pay the actual market-clearing price in each period for their actual purchases, and that price may differ from the forecasted price.

In all of these experiments, suppliers are free to engage in whatever offering behavior they would like, short of formal discussions about their offer strategies with their competitors. One purpose of these experiments is to understand to what extent electricity markets might become more self-regulating, economically, were widespread customer participation to become prevalent. This analysis explores the extent to which the electricity system becomes more predictable, physically, as the customers achieve greater involvement.

## 2. Buyer's Problem

To keep the demand-side decisions simple for the participants, each buyer is assigned a simple two-step discrete demand function with separate valuations for day and for night usage, as shown in Figure 1. In fact, these individual demand relationships are decomposed from an aggregate demand function that has a retail price elasticity of demand, at the mean price, of  $-0.3$ , Faruqui and George [2]. Nineteen different buyers are included in each experiment, each with different assigned valuations. Furthermore, the overall demand function ranging from very low prices to the reservation price was given the inverted S-shape suggested by Schulze's work (reported by Woo, et. al. [4]) on consumer value loss for interruptible service.

Note that each customer's daytime valuation is somewhat higher than his or her night valuation. Furthermore, there is an additional "substitutable" block of energy that customers can choose to buy either during the day or the subsequent night period (unused substitutable energy cannot, however, be carried over to the next day/night pair of periods). Typically, substitutable electricity purchases are valued less than the regular purchases in each of these periods, and substitutable night energy is valued less than if it is used during the day. These substitutable blocks were also decomposed from the aggregate demand curve that has an elasticity of substitution between day and night usage of  $0.3$ , Faruqui and George [2]. Thus, the buyer is confronted with an inter-temporal optimization problem. In addition, these induced valuations are increased substantially in pre-specified periods called "Heat-Waves" to reflect the added value of electricity in extreme climatic conditions. The buyer's problem then is to maximize the spread between their assigned valuation for each quantity of

electricity they buy, and the price they have to pay for it. Thus if all consumers behave optimally in these experiments, the total system load should be grouped around four distinct levels, representing normal and heat wave, day and night periods, each.

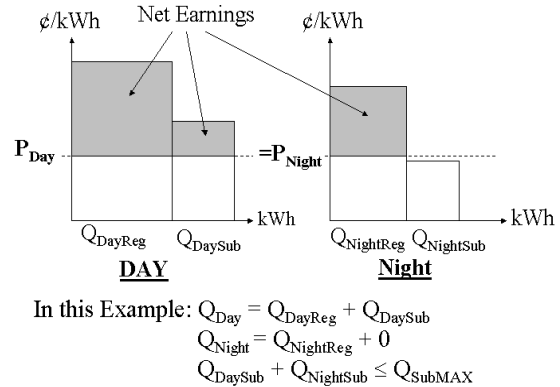

Figure 1. Illustration of Buyer's Problem

## 3. Seller's Problem

Each of the six active suppliers is assigned three different generating units with different constant incremental production costs (20 MW @ \$22/MW, 15 MW @ \$50/MW and 20 MW @ \$ 61/ MW). In addition there is a fixed cost associated with each supplier's total capacity that must be paid regardless of the supplier's level of activity (\$20 per market period per generating unit, or \$60 per supplier). The supplier is free to offer as much or little capacity into the market, up to the total capacity limit on their generation, as they wish, and they can specify a different price for each of the three different blocks of power that they can offer into the market. Offers may be made at prices lower or higher than the incremental production cost. The discretionary cost each supplier can choose is associated with whether or not and how much capacity they offer into the market. Each MW offered bears an opportunity cost of \$5.00, regardless of having been selected to generate. This opportunity cost represents the commitment of resources and/or cost of foregone maintenance that is associated with planning to have those units available, as reflected in making an offer. The seller's problem is illustrated in Figure 2, and since the market in each period clears at the highest offer needed to meet the market demand, all suppliers with offered prices at or below that level are paid the identical last (highest) accepted offer. Each seller earns a profit in each period equal to the market price times the quantity they sell, minus the incremental cost of generating the electricity they sell, minus the \$5.00 opportunity cost

times all of the energy they offer into the market, minus their fixed costs.

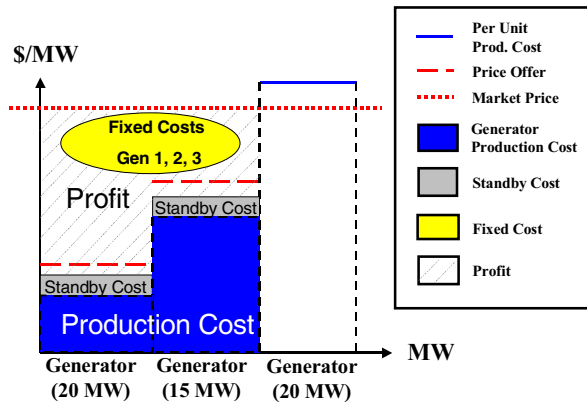

Figure 2. Illustration of Seller's Problem

#### 4. Market Structure and Calibrations

In these two-sided markets, 19 buyers and 7 sellers were included. However the seventh seller was represented by a computer-simulated agent with a single 30MW block of low-cost \$25/ MW generation (representing a base-load unit) that was always offered at cost, so the \$5/MW opportunity cost of making offers is already included in the \$25/MW. This unit was the only generator subject to random outages, and its behavior was simulated numerically so that none of the six active participants would feel that their earnings were biased by a random phenomenon. Each of the buyers was assigned a different set of valuations for the energy they could purchase, and for approximately 80 percent of the buyers, those values were set very high but realistically, based upon previous empirical work (see Woo et. al. [4]). Therefore, the optimal quantity purchases would not change for this majority of buyers unless the market-clearing prices reached levels many multiples higher than those anticipated. Given the popular sentiment that "most" buyers are not interested in altering their electricity consumption, this assignment of values acknowledges that assertion. It also provided experimental flexibility when some anticipated subjects did not appear for assigned sessions; they were replaced by numerically simulated agents that were assigned valuations that were well above those anticipated to be at the decision-making margin. Thus, human subjects were always assigned to the role of the twenty percent of buyers with valuations that appeared at the margin in one or more periods. In fact the number of human buyers ranged from 13 to 17 out of a total of 19 in each of these two-sided experiments.

Three demand-side treatments were tested, FP as the base-line, DRP and RTP. Each treatment was run over the

identical eleven day-night pairs (22 periods, total) with the same sequence of combinations of normal periods, heat-waves and unit-outages. DRP was triggered by any predicted retail price that exceeded \$.106/kWh (\$66/MW wholesale price) so that speculative behavior on the part of suppliers might also initiate this program. The average market demand in these experiments was designed to be approximately 200 MW (lower at night, higher during the day and in heat waves), and 330 MW of active supply was available, plus the 30 MW provided by the numerically simulated base-load unit, when not subject to a random outage. The wholesale market was cleared at and all accepted suppliers were paid the uniform price of the highest (last) accepted offer. Demand was always met, despite withholding, because of the availability of purchases from external sources, which all participants were told about. What subjects weren't told ahead of time was when those sources would be used and at what price (thus external purchases were to represent market-based purchases from outside the system), but all participants were informed of the market-clearing wholesale price after each period. In fact whenever demand could not be met from internal supplies, or whenever the estimated wholesale price exceeded \$150/MW, those external purchases were invoked from the generator outside of the system whose cost was \$72/MW. Whenever that import generator was called upon, they set the wholesale market price at the lower of 1) \$150/MW, or 2) the last accepted internal offer plus an increment ranging between \$5 to \$15 that was selected randomly in each instance. The objective was to avoid having suppliers withhold capacity specifically in order to have the import generator set the wholesale price (in effect transforming a hidden price cap into a price floor).

##### 4.1. Market Sequence

Each market period began with the auctioneer (ISO/RTO) providing fair load forecasts (quantities) for the upcoming two (day-night pair) periods. All buyers and sellers were told before each day-night pair whether the upcoming period had normal or heat-wave conditions, and whether or not a unit outage had occurred. Next the suppliers would submit their price-quantity offers for both of the day-night periods. Then, either price forecasts or firm prices and/or anticipated market conditions were given to the buyers. Under FP, the retail price was always set at \$.085/kWh, which includes a \$.04/kWh wires charge, regardless of wholesale market conditions. Under the DRP treatment, the same fixed price of \$.085/kWh was charged for all purchases, but when DRP was announced to be in effect, a \$.079/kWh credit for purchases below each buyer's announced benchmark consumption level was provided. These fixed prices and DRP credits differed from the amounts in the previous

single-sided market experiments because of the fewer increments of cost assigned to suppliers in these two-sided experiments, but the range of demand valuations remained the same. Under the RTP treatment, a fair forecast of market clearing prices for the next day-night pair was announced, based upon market conditions and the suppliers' offers. The buyers then made their quantity purchases, suppliers were committed and the market clearing wholesale prices were declared. In the case of RTP, buyers were told the actual price they were assessed for their purchases in each of the previous day-night periods, which however didn't vary more than twenty percent from the forecast prices for those periods. Finally, each seller was told their earnings, and each buyer was apprised of the net value of their purchases, including DRP credits where applicable. The process was then repeated for the next day-night pair until all eleven pairs were completed.

Load forecasts were always based upon buyers' performing optimally at the fixed or forecast prices. The \$.085/kWh retail price was based upon an estimate of cost-based offers by suppliers and optimal purchases by buyers. The DRP credit reflected the saving in supply, at production cost, to the reacting customer plus a pro-rata share of the cost-based savings to the market. The price forecasts for the RTP treatment used the suppliers' actual offers and presumed the buyers would behave optimally.

Since retail prices and/or DRP credits were pre-specified and fixed under the FP and DRP treatments, there is no guarantee that the revenues collected from the buyers, minus the \$.04/kWh wires charge, would match the wholesale market obligations to the sellers. Therefore, after each of the first two treatments (FP and DRP), the change in retail price that would have been required to balance the ISO/RTO's budget was announced. In the case of RTP, no rate adjustment is required since buyers pay the actual market-clearing prices for their purchases.

#### 4.2. Preference Polls

A poll was conducted after each of the three treatments in which the participants were asked which of two treatments they preferred: DRP or RTP. The poll was conducted and results tabulated before the subjects had any experience with either treatment, again after they completed the DRP treatment, and then again after they completed both DRP and RTP. The required adjustments in retail prices were also announced after the FP, and again after the DRP treatments, but before the respective preference polls were conducted. What differed about the final poll is that the participants were told that based upon a majority vote, they would play four additional day-night pairs using the treatment (DRP or RTP) they selected. Furthermore, in this final round they were told that their exchange rates (always  $< 1.0$  to keep the cost of the

experiments within the researchers' budget, but different for every participant so each had an equivalent chance to make the same money despite different costs and valuations) would be adjusted so that they might anticipate earning as much money for this final four period round as they had in the earlier sessions that covered eleven day-night pairs.

#### 4.3. Selection of Subjects, Training and Compensation

Since a primary issue addressed in these experiments is the extent to which the introduction of active demand-side participation in these markets might reduce the exercise of market power by suppliers, it was essential to have subjects acting as generators who knew how to speculate and lift prices. In prior experiments advanced undergraduates and graduate students had demonstrated after sufficient experience that even six suppliers who were prohibited from exchanging information outside of the context of the market, and where only market-clearing information was provided, could nevertheless raise prices substantially above competitive levels.

Even after separate training sessions for prospective sellers, several trial runs were made on each market treatment before that treatment was begun, and all questions by buyers and sellers were answered and communicated to all subjects before the actual experiments began (all questions that arose during the experiments were also answered privately). Thus the entire experiment lasted several hours on each of three separate evenings: one session for training, one to run FP and DRP treatments and one for RTP plus the final four high payment rounds using the treatment selected by the subjects.

All participants were paid in proportion to their total earnings. In the first experiment conducted late in 2003, 17 active buyers and 6 sellers participated, and they earned an average of \$49.27 in their training session and \$66.15 in the two experimental sessions (\$91.47 was the highest; \$10.53 the lowest). Only one buyer did not complete all trials, but since their valuation of purchases was extremely high, a computer agent was substituted in the absent rounds. All 13 active buyers and 6 sellers who began the April 2004 identical experiment completed it. In all cases, spare extra subjects who were trained as sellers were paid to appear at each experiment, but they were never called upon to participate. In the second experiment the average payment during the training round was lower, \$22.32, but the average payment during the two experimental sessions was \$62.09, nearly identical to the earlier payments, although the spread was smaller (\$74.09 was the highest; \$34.55 was the lowest). Because each buyer had different assigned valuations for their

purchases, and to ensure that all participants, whether buyer or seller had an equal opportunity to leave the experiments with the same amount of money, different exchange rates were assigned to the nominal earnings of each participant.

## 5. Experimental Results for Two-Sided Markets

### 5.1. Overall Efficiency and Differences in Behavior

Consumers' surplus, producers' surplus and total market efficiencies are summarized in Table 1 for the DRP and RTP treatments as a percentage of the wholesale revenues under the FP treatment. As a benchmark, the theoretical socially optimal levels of efficiency are also presented, and the combined data indicate that a 6.75 % overall gain, compared to a FP system without regulatory controls on suppliers, is possible. Both DRP and RTP also provide welfare gains to consumers, but in the case of DRP the offsetting loss to suppliers is so great that there is a net welfare loss; whereas with RTP, a combined gain of 2.02% is obtained. In general, the large price spikes generated under the FP system are muted by the RTP and DRP treatments, as shown elsewhere (see Adilov, et. al. [1]).

Most of the substantive differences in quantities consumed by buyers between the different pricing schemes shown in Table 1 are statistically significant. Buyers consume less electricity in all periods under DRP, as compared to FP; whereas, under RTP customers buy more electricity at night and less during the day than under FP. Furthermore, the last column emphasizes the overall conservation effect of DRP since it results in a statistically significant reduction in purchases both during the day and at night, as compared to RTP. Unfortunately, this is inefficient as highlighted by the quantity comparisons between DRP and RTP with the socially optimal level of consumption: under DRP too little electricity is purchased in all periods; whereas, consumption under RTP was not significantly different than the optimal levels, except during normal day periods when too little was purchased. Similar results are shown for the suppliers' quantities, since supply always equals demand, but the statistical tests are somewhat less significant for sellers because of their smaller number.

**Table 1. Two-Sided Experimental Results: Overall Efficiency for Combined Trials**

**1. Deviations Re-Stated as % of FP Revenues without Regulation:**

	% Added Consumer Value	% Changes Supplier Profit	Combined Change
RTP	9.02	-6.99	2.02%
DRP	13.86	-17.52	-3.67%
Social Optimum (as comparison)	29.32	-22.57	6.75%

**2. Statistically Valid Differences in Behavior from FP Results (@ .95 level):**

Value/Profit Quantities Bought/Sold:	RTP vs. FP		DRP vs. FP	
	Consumers	Sellers*	Consumers	Sellers*
Days	+	-	+ ?	-
Nights	-	- ?	-	-
	+	+ ?	-	+ ?

\*Note: With fewer sellers, statistical significance is harder to attain.

### 5.2. Participant Preferences

In both groups that participated in this experiment, there is a reversal of stated preferences from preferring DRP to selecting RTP as experience is gained with both. The first group switched from 74% preferring DRP initially to 64% preferring RTP afterward, a statistically significant reversal. The second group's reversal was less appreciable, moving from only 53% preferring DRP ahead of time to 68% preferring RTP after having tried both. However the final fraction that preferred RTP was similar in both groups and reflects self-interest, since the results of the final poll were used to select the demand-side treatment that was used in the last four rounds with high-stakes payoff potential. In particular, suppliers were unanimous in selecting RTP for the final rounds.

### 5.3. Line Flow Predictability

In a preliminary analysis of line flow implications from these experiments, the correlation between total system load and line flow appears to re-emerge under DRP and RTP, as contrasted with FP. Figure 3 illustrates the PowerWeb 30 bus electrical transmission network that underlies these experiments. The location of all generators is shown, including the import generator that cleared the market when insufficient internal supplies were offered, and the buyers are distributed across the remaining busses.

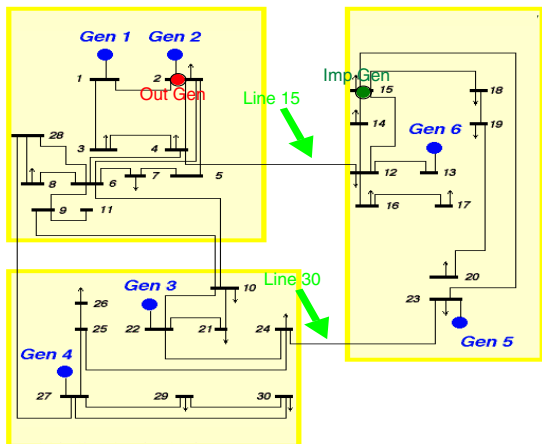

**Figure 3. Power Web Simulated Electricity Network with Monitored Lines**

The variation in power flows on each of the 39 transmission links in this network are plotted in Figure 4 for each of the three demand-side treatments examined in these experiments. Both the socially optimal line flows and an estimate of those flows that would have been observed under the former regulated regime (cost-based dispatch to meet the demand represented by the FP system, the demand structure widely employed under the prior regulated regime) are also included as benchmarks. Line 15 has the greatest variability under all regimes, since that is the location where the import generator feeds into the network when there are shortages, and that line is also linked to the generator that experiences random outages. In general, greater variability is associated with the market-based FP treatment, but those swings seem to be lower on most lines for DRP and RTP, approaching the levels of the former regulated regime.

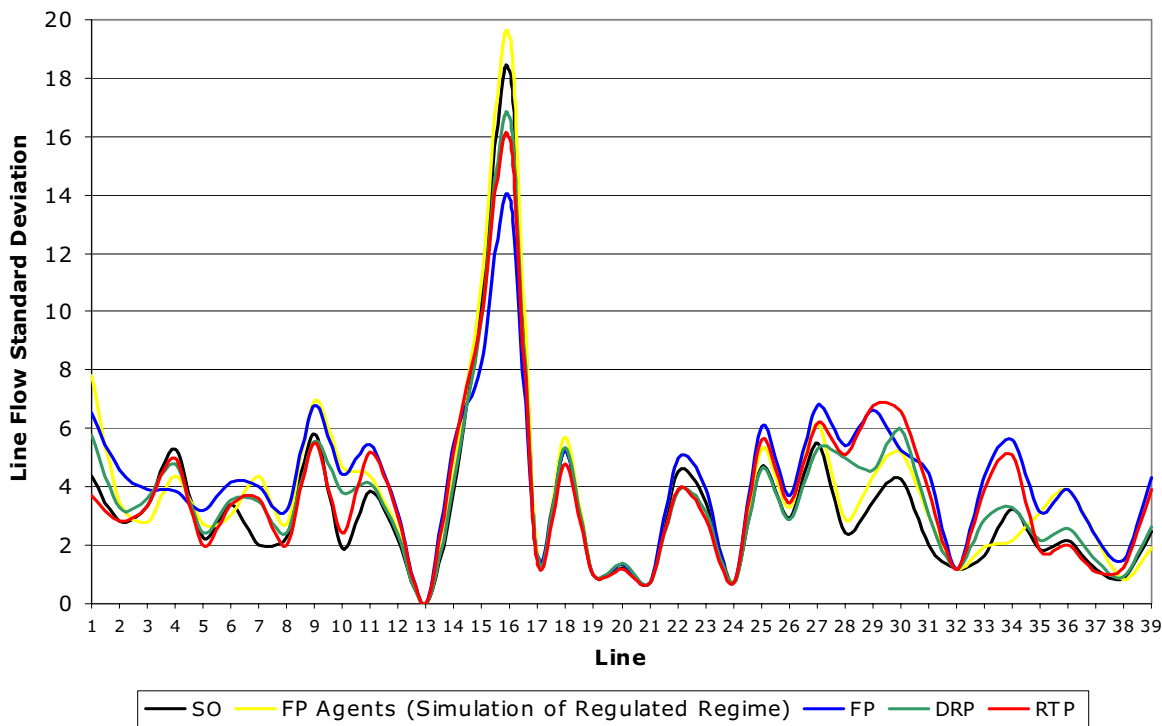

**Figure 4. Line Flow Standard Deviation by Treatment Using Pooled Data From Experiments 1 and 2**

Two of the lines were selected (line 15 with the greatest variability and the more typical line 30), and a statistical test was performed on the correlation between system load and line flows on those links, for all five cases illustrated in Figure 4. These regression results are summarized in Table 2. Because of the location of the import generator, there is actually a negative correlation between system load and the flow on line 15 (as system load increases, the probability of calling on imports increases which serves the load in the right-hand side of the system and reduces flow on that particular line), but that negative relationship exists under all five regimes. What is different is the magnitude and the degree of statistical significance of that relationship. The relationships are nearly identical under the socially-optimal, previously regulated and RTP regimes; the

association is weakest under the FP market case, but improves somewhat under DRP.

In the case of a more typical transmission link like line 30 where there is a positive relationship between system load and line flow in all five cases, once again the socially optimal and former regulated regimes yield almost identical results. Here, the relationship becomes much weaker under the FP market regime, becomes almost identical in magnitude, but not in statistical significance under DRP, and becomes even stronger under RTP, although still not as significant statistically. Thus operators of electrical systems may also find value in the widespread implementation of demand side participation if it strengthens the predictability of flows on any particular line.

**Table 2. Statistical Relation Between Line Flows and System Load**

	Social Optimum	(Reg. Regime) Fixed Price with Regulated Sellers	Results with Active Participants		
			Fixed Price	Demand Reduction Program	Real Time Pricing
<i>Regression Results for Tie Line 15</i>					
Intercept	40.1779	39.1761	17.9780	29.9462	33.0568
Std Err	3.0375	2.1514	3.1385	3.8662	3.5013
Slope Coefficient	(0.1982)	(0.1901)	(0.1025)	(0.1789)	(0.1909)
Std Err	0.0167	0.0116	0.0168	0.0236	0.0197
R-Squared	0.7701	0.8657	0.4695	0.5777	0.6906
F-Statistic	140.6651	270.7614	37.1714	57.4517	93.7394
P-value	0.0000	0.0000	0.0000	0.0000	0.0000
<i>Regression Results for Tie Line 30</i>					
Intercept	(17.5262)	(18.5527)	(9.1573)	(13.9666)	(17.5818)
Std Err	1.5631	1.7259	2.4566	3.0202	3.1587
Slope Coefficient	0.0751	0.0753	0.0437	0.0802	0.1024
Std Err	0.0086	0.0093	0.0132	0.0184	0.0178
R-Squared	0.6449	0.6111	0.2079	0.3104	0.4409
F-Statistic	76.2617	66.0048	11.0260	18.9069	33.1193
P-value	0.0000	0.0000	0.0019	0.0001	0.0000
Note: The following linear regression equation was estimated with OLS.					
Line Power Flow = B <sub>0</sub> + B <sub>1</sub> x System Load					
N = 44 for all regressions					

## 6. Conclusion

These experimental results demonstrate the successful construction of a realistic demand-side platform that can be used to test a variety of hypotheses about buyer and supplier behavior in two-sided electricity markets. These markets are not trivial, and substantial training was required to get subjects representing six sellers who were able to lift prices well above competitive levels under the fixed, constant retail price regime that is used in most locations around the country. All markets were conducted without price caps, prohibitions on withholding supplies or automatic mitigation mechanisms. Nevertheless, when pitted against these trained sellers, less sophisticated buyers with fairly simple demand-side mechanisms, representing pre-set demand response programs or real time pricing regimes, were able to mute much of the suppliers' exercise of market power without any regulatory interventions. Not only did real time pricing lead to the highest overall efficiency of these three market regimes, a majority of participants opted to use real time pricing going forward, including sellers, after having gained experience with that system.

Finally, the predictability of electricity flows on several transmission lines was explored as a function of overall system load for these three two-sided market regimes and under a simulation of the former cost-based regulatory regime. That relationship deteriorates substantially under the FP market regime, is partly re-established under DRP, and under RTP once again resembles the predictability that was previously available

to system operators under regulated power pool exchanges. Thus, achieving far greater active customer participation in these electricity markets may ease the task of the system operators, as well as reduce the extent of market power surveillance.

## 7. References

- [1] Adilov, N., Light, T., Schuler, R., Schulze, W., Toomey, D., and Zimmerman, R., "Self-Regulating Electricity Markets," presented at the Advanced Workshop in Regulation and Competition, Rutgers Center for Research in Regulated Industries 17th Annual Western Conference, San Diego, June 24, 2004.
- [2] Faruqi, A. & George, S., "The Value of Dynamic Pricing in Mass Markets", *The Electricity Journal*, July 2002, pp. 45-55.
- [3] Thomas, R., "Markets and Reliability", Report to Consortium on Electricity Reliability Technology Solutions, Washington, D. C., Jan. 2002.
- [4] Woo, C-K., Pupp, R., Flaim, T. & Mango, R., "How Much Do Electric Customers Want to Pay for Reliability? New Evidence on an Old Controversy," *Energy Systems and Policy*, 15, 1991, pp. 145-159.