

The Burroughs 220 High-Speed Printer System

F. W. BAUER† AND P. D. KING†

INTRODUCTION

IN the past few years, computer manufacturers have been developing and delivering data processors with faster and faster processing speeds. Less attention, however, has been paid to getting printed information from the data processor. As a result, most data processing systems are input/output bound.

The speed of the printing device has not been the only restriction; expensive and time-consuming central processor runs were necessary to perform the editing and formatting of the information for the printed page.

In order to bring about a system balance and relieve the central processor of unnecessary data manipulation, a high-speed printing system with complete off-line editing was needed.

To define the problem more closely, we studied such applications as: the printing of insurance premium notices and declaration forms; wholesale drug and grocery billing, oil company and public utility billing; and the preparation of bank statements, stock transfers, and dividend checks. To handle these applications, a printer system must not only be fast but also—considering customer relations—capable of producing a neat legible document.

SPECIFICATIONS

The high-speed, large-volume, complex-editing application, then, was the general framework which defined the boundaries of our system planning.

First of all, the new printer system must be a high-speed device, capable of producing the printing requirements of a majority of applications. The necessity for system speed established the need for independent printer control of format and editing, since high-speed output which depended on extensive editing by the data processor could not be considered true speed at all.

Independent operation and speed requirements indicated that magnetic tape was the logical choice for communication between the central processor and printer system. By using magnetic tape as a buffer, printing as far as the central processor is concerned, is at magnetic tape speeds; the central processor need never wait for the printing device to accomplish its task.

To provide further versatility it was deemed advisable to allow the printer system to work directly with the central processor for those applications requiring on-line operation.

As a final requirement we decided we would not want to prepare special print tapes for off-line operation or require central processor time for editing when on-line.

In either case our obvious aim was to reduce the amount of data manipulated within the central processor. Printing from master tapes or records was a must.

This, in brief, is the application framework within which we established the performance specifications of our new printer system. The term “printer *system*” is significant. In this case, terminology was dictated by a desire to describe accurately the operation of the units, independent of direct processor control.

GENERAL DESCRIPTION

The Burroughs 220 High-Speed Printer System (Fig. 1), is a transistorized, buffered, on-line/off-line subsystem with versatile editing capabilities controlled by a plugboard. The system, which includes a Printer Control Unit and a Printing Unit, is designed to operate on-line with the Burroughs 220 Data Processor, or off-line with one or two standard Burroughs 220 Magnetic Tape Storage Units.

Control Unit

The Printer Control Unit (Fig. 2), houses an 1100-digit, random-access core storage used as a buffer, which accommodates up to 100 computer words (10 digits plus sign). The Control Unit also contains the system's control circuitry, a 120-character print register, a 120-position bit register, the transistor power supply, and the plugboard.

Printing Unit

The Printing Unit contains a drum-type, high-speed printer (Fig. 3), having 120 print positions, with 10 characters to the inch, and a total of 51 characters per print position. Of these, 15 are special characters, including CR, OD, DR, + and - symbols.

The Printing Unit (Fig. 4), also contains paper motion controls and the power required to drive the printing mechanism.

Vertical line spacing is fixed at six lines to the inch. Printing can be positioned any place on a 16-inch form. The printer can accommodate a maximum form width of 20 inches for centered printing. The maximum form length is 22 inches. The printer can print an original and five carbon copies.

Complete control of paper skipping (Fig. 5) is accomplished by means of a seven-channel punched paper tape loop, $\frac{7}{8}$ inch wide and photoelectrically sensed. The paper tape loop provides six predetermined paper skip positions and a carriage exit position, which is used primarily for page overflow or for logical decisions. Thus, jumping to and printing header information on the next form is easily programmed.

† ElectroData Div., Burroughs Corp., Pasadena, Calif.

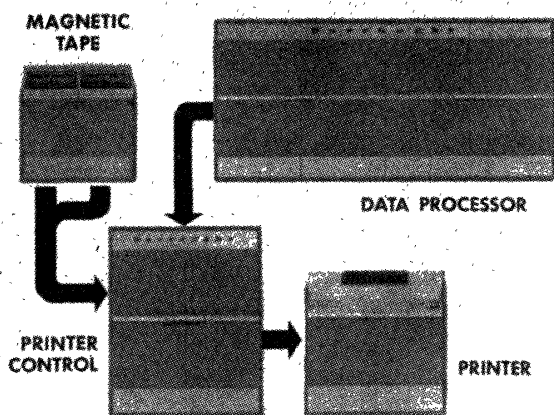

Fig. 1—Burroughs 220 High-Speed Printer System.

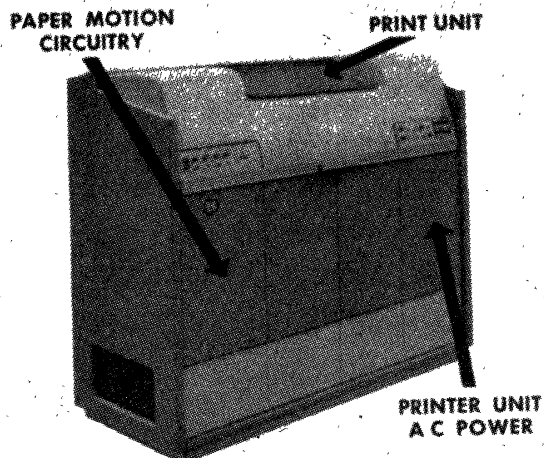

Fig. 4—Printer unit.

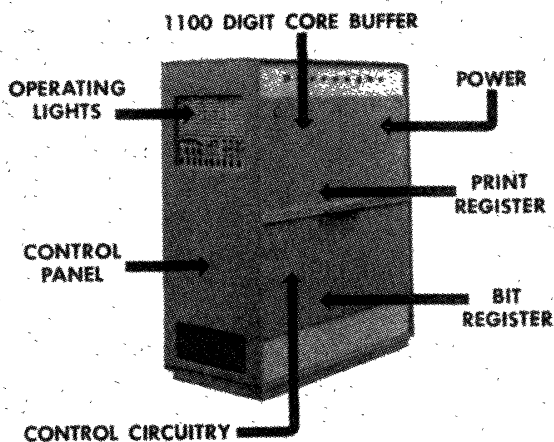

Fig. 2—Control unit.

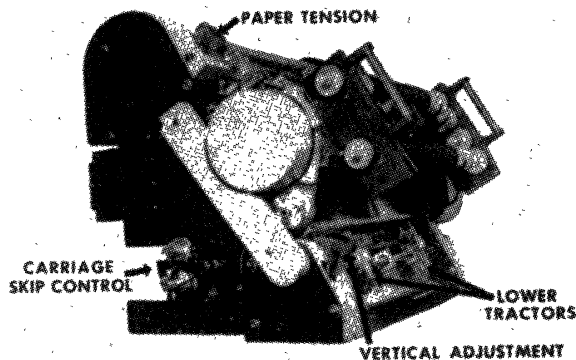

Fig. 5—Printing unit, side view.

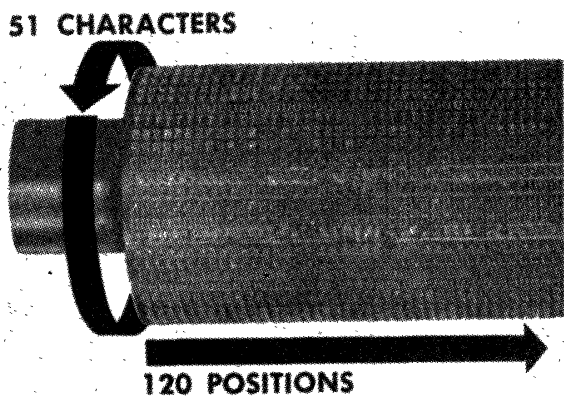

Fig. 3—Print drum.

Under plugboard control, page-skipping and single- or double-line spacing before and after print allows easy accommodation of preprinted forms. Paper moves at the rate of 25 inches per second, with 9 msec start-stop time for a single-line space time of 16 msec.

The printer may be operated at print drum speeds of 750, 900, 1500, and 1800 rpm. The effective printing rate is dependent upon the information to be printed. For alphanumeric information, the effective printing

rates are 624, 720, 1068, and 1225 lines per minute. If only numeric information is to be printed the effective printing rates automatically become 750, 900, 1500, and 1225 lines per minute.

These higher numeric print speeds are accomplished by detecting in the control unit during the loading of the print register that only numeric information is to be printed. (See Fig. 6.) When this condition exists the control unit terminates the print cycle at the end of the numeric section of the print drum rather than requiring a full drum revolution. The time required to traverse the remainder of the print drum, the alphabetic section, is used by the printer system in spacing paper and reloading the print register.

It can be seen that at the top drum speed of 1800 rpm the printing rate is only 1225 lines per minute for numeric information, the same as for alphanumeric information. This is because the time required to load the print register or space the paper is greater than the time required to traverse the alpha section when the print drum is rotating at 1800 rpm.

Fig. 7 is a front view of the print unit showing horizontal paper positioning controls, vertical paper positioning controls, paper tension controls, the ribbon mechanism, and the upper and lower set of form tractors. Lateral positioning of printing and form size ad-

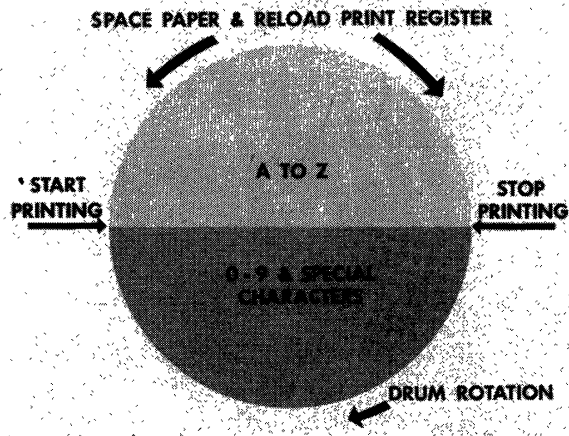

Fig. 6—Character arrangement on print drum.

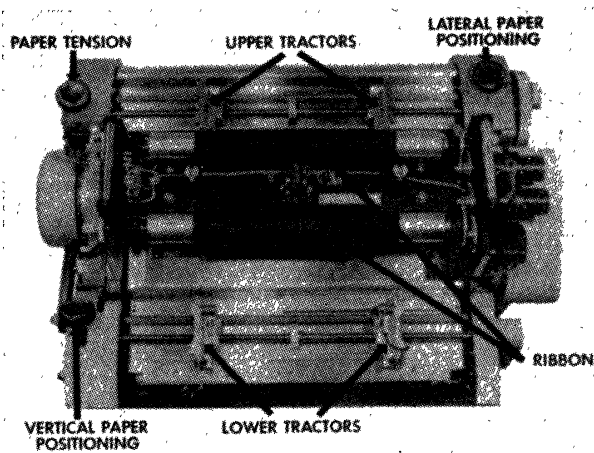

Fig. 7—Printing unit, front view.

justment are accomplished with the control in the upper right of the picture.

Controls are available for moving all tractors to the right or left in synchronism for positioning of printing on the page. In addition, controls are available for moving either the right or the left set of tractors individually for accommodating form width. Paper tension between the upper and lower sets of tractors is controlled by the upper left control knob. By using two sets of tractors, the upper and the lower, and positive mechanical detenting, paper creep is eliminated. Fine vertical adjustment within a line is accomplished with the lower left control knob.

OPERATION

With some of the details out of the way, we can now push a few buttons and see how the Burroughs 220 High-Speed Printer System works. The internal operation of the system is divided into three basic cycles (Fig. 8):

1) Load cycle—During the load cycle, the core buffer is loaded from magnetic tape or from the Data Processor.

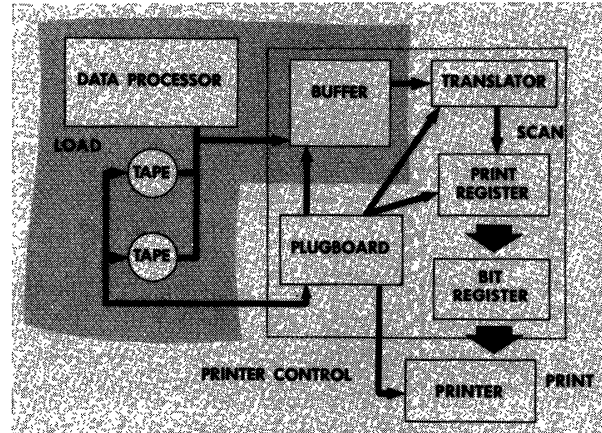

Fig. 8—System flow diagram.

2) Scan cycle—The scan cycle is basically the transferring of selected information from the buffer to the print register. During the scan cycle, all editing, formatting and selection is accomplished. The scan cycle is normally completed during paper spacing time.

3) Print cycle—During the print cycle the line of information is transferred from the print register to the paper. Since the core buffer is not used during the print cycle, the load and print cycles can occur simultaneously.

Load

When used off-line, the load cycle is initiated from the plugboard. Information is read from one of two magnetic tape units. The block length on tape is variable from 10 to 100 words and can be variable within a run. The number of blocks read per load cycle is selected from the plugboard, the only restriction being that no more than 100 words can be loaded into the buffer at any one time. If the capacity of the buffer is exceeded, a buffer overflow alarm is available on the plugboard for automatic corrective action if needed. Selection of the storage area to which the information will be sent is plugboard controlled. As a result, it is possible to have in the buffer at one time any combination of information from 2 tape units and the data processor.

When used on-line, loading of the buffer is controlled by two commands from the data processor. The first command is used to determine if the printer system is ready to accept information. The second command loads the buffer with a record from 1 to 100 words in length. Once loaded, the data processor is freed.

Scan

The scan cycle is so named because information to be printed is not transmitted by plugboard wires but rather by internal channels. The scan cycle includes the transfer of selected buffer information through a translator to the print register for subsequent printing. All editing of information is accomplished during this phase of the printer operation. The plugboard wiring is used

for decision making, selection of starting positions of fields, special character insertion, editing, and formatting functions.

During scan, the starting position of a field is selected; the field then reads out sequentially to the print register, with no restriction on field length, and continues until ordered to a new starting location. After a change of address has been ordered the scan continues sequentially from the new address. The addressing of the buffer is controlled by a counter called the character address counter, which changes the location when set to a new value. Fig. 9 illustrates the operation during the transfer of one digit from the buffer to the print register. The character address counter selects the digit to be transferred, out of 1100 possible settings. For each one of these settings there is an exit hub on the board. These exit hubs are the source of control pulses, to cause address selection, formatting and control. Other functions which can be initiated by these pulses include zero suppression and the insertion of blanks, commas, decimal points or dollar signs. A feature which helps reduce the amount of information to be manipulated is the character emission of all 51 characters for printing of fixed information—the date, for example.

When information is read out of the buffer, the digit value is available on the plugboard and can be used for controlling and testing purposes. Digits so used need not be printed; for instance, decisions whether to print a record or not can be based on the digital value of a key.

The scan cycle is automatically terminated when the print register has been filled with 120 characters, and a print cycle is automatically started. At this time an end scan pulse is available for initiating a buffer load if desired.

Print

At the time the print cycle starts, the print register is filled with a 120-character line. There is a counter synchronized with the rotation of the print drum which tells at any instant the next character on the drum in position to print. By comparing each position of the print register with this counter the positions to be printed are determined. At the start of the print cycle this comparison process begins immediately (Fig. 10).

To illustrate, if the counter were at a value corresponding to *R* all *R*'s in the print register would be printed first. When the print drum has rotated through one position and the counter advanced to *S*, all the *S*'s will be printed and so on. The print cycle will be completed in this case when the print drum has rotated back to *R*. The printing actually occurs by timed firing of print hammers. The 120-position bit register contains the "yes" or "no" of whether the print hammer associated with a particular print position will fire at a specified character time. Loading the bit register is accomplished by means of the print register comparisons just mentioned.

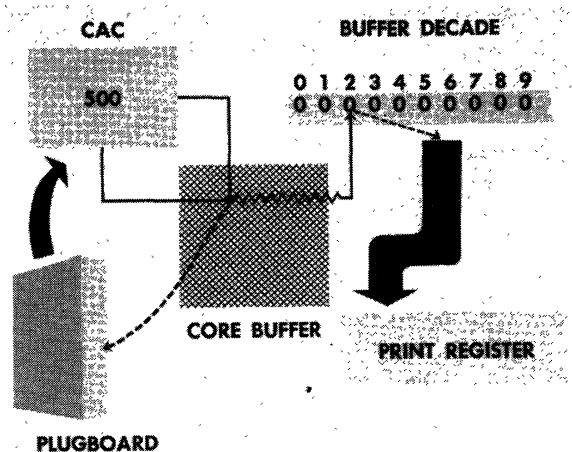

Fig. 9—Buffer readout.

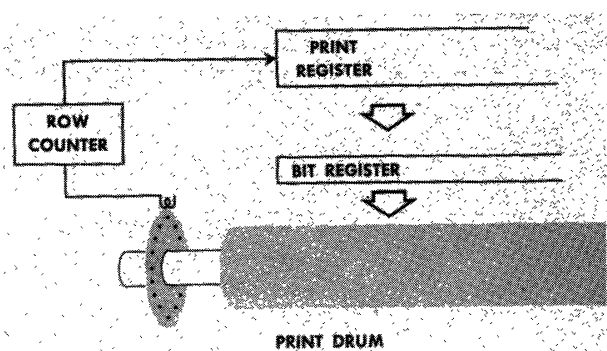

Fig. 10—Print cycle.

If spacing is wired on the plugboard to occur after printing, paper spacing will start immediately after the print cycle. A start scan pulse is available on the board to start a new scan cycle, assuming no load cycle is taking place. If a load cycle is not yet completed, the start scan impulse will be held up until it is. However, a load cycle will normally be completed during a print cycle, except at the highest drum speeds.

SPECIAL FEATURES

This, in essence, is the Burroughs 220 High-Speed Printer System. We will look next at some of the special features of this system. Fig. 11 lists the functions available to complete the editing ability and enable printing from master tapes; these are initiated by character address pulses.

The special features of the Burroughs 220 High-Speed Printer System are described in the following paragraphs (Fig. 12).

Wiring by Exception

The control panel need only be wired when information is to be printed out in a different sequence than that contained in the buffer. In this case, the character address pulse of the last digit of a field to be transferred is wired to address the starting position of the next field.

1. Zero suppress
2. Check protecting asterisk insertion
3. Comma and decimal point insertion
4. Insertion of blanks
5. Delete
6. Special sign translation to +, -, CR, OD, DR

Fig. 11—Special functions.

1. Wiring by exception
2. Field selection
3. Exception or selective printing
4. Field interrogation
5. Multiple line printing
6. Retention of fixed information
7. Relative addressing

Fig. 12—Special features.

Thus, field selection is accomplished. Since it is not necessary to provide plugboard wires for the transmission of all positions of a field the actual number of plugboard wires is reduced to a minimum.

Exception or Selective Printing

Transferring the digit value of the contents of a buffer location to the plugboard during transfer of information to the print register allows recognition of keys within the information. Thus, logical electronic elements cause or prevent printing. For example, when printing paychecks, the plugboard can be wired to print checks for only those employees with earnings, ignoring all employees with no earnings.

Field Interrogation

Logical decisions can also be made by comparing buffer information to preset information in 10 rotary switches. For example, in a statement preparation application, the date would be set in the switches. Only those accounts scheduled for that date would have a statement printed. All other accounts would be skipped.

Multiple Line Printing per Buffer Load

Because the buffer is actually a storage device, any number of lines can be printed from one buffer load. Repeat printing of any information is possible. Complete documents can be prepared with one reading of the tape record.

Retention of Fixed Information

The ability to select the starting address during load enables the retention of information in the buffer, for example, page heading information. This feature is particularly useful when multipage documents are to be printed.

Relative Addressing

(See Fig. 13.) This is a form of indexing register which enables grouped records to be printed in the same format with wiring for only the first of the records. The

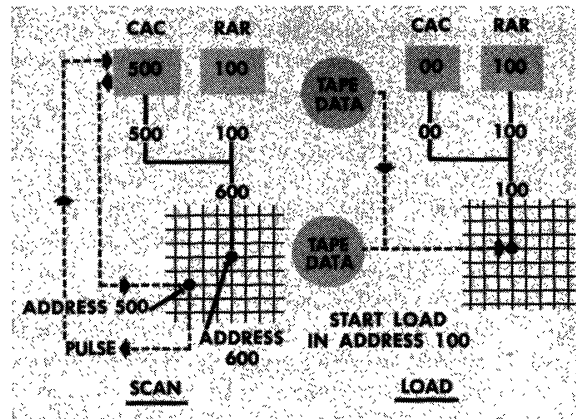

Fig. 13—Relative addressing.

character address pulses are always governed by the character address counter. However, the information is available from the buffer position determined by the sum of the setting of the character address counter and the relative address register. Thus, by changing the value of the relative address register, different information can be read out of the buffer with the same value of the character address counter. This feature allows side-by-side printing without duplication of wiring.

It is the relative address register which determines the starting address during a load cycle. The character address counter is always set to zero at the start of a load cycle. As during the scan cycle, the sum of the character address counter and relative address register accesses the buffer.

CHECKING

Complete checking of all information transfer and programmer control of error conditions are provided. Fig. 14 shows the checking points and methods within the system.

During load, each digit is checked for parity and invalid combinations. In addition, a check is made on the number of digits in the tape record. If any error is detected, the tape is automatically reread and an error signal emitted from the board. If an error persists after two retries, the system automatically stops, unless programmed to ignore this stop or to take other remedial action.

Parity is checked during the transfer from the buffer to the print register through the translator. Parity and invalid characters are checked again in the translator, and errors are indicated on the plugboard.

During printing, another parity check is performed with errors again indicated on the plugboard. In addition to parity checking during printing, a synchronization check is made which insures that the print position was fired at the correct time for a given character. This print check feature (Fig. 15) works as follows.

A reluctance emitter in the printer counts a row counter. This counter determines the character to be read out. A home pulse from a second reluctance emitter is

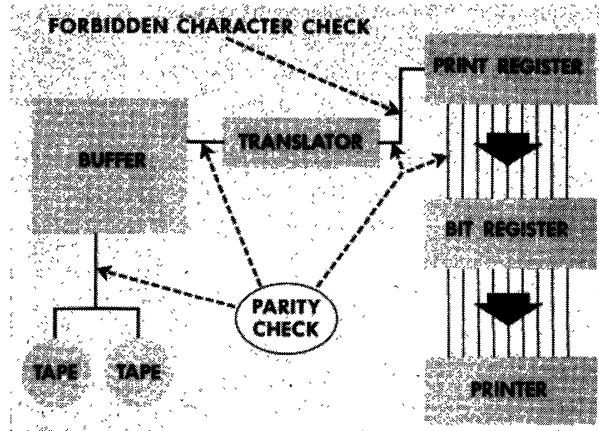

Fig. 14—System checking.

compared with the row counter when the latter's value is at zero. If the two are out of synchronization, the system automatically halts.

This is the only checking feature which cannot be ignored; the print check alarm is not available on the plugboard.

All error checking alarms that are available on the plugboard can be used to cause retries or brute-force operation which can be flagged on the printed page. Thus, in every case but one, the programmer, not the machine, decides whether an operation is to be halted or not. Oftentimes, the programmer will want to wire automatic restart procedures on the plugboard.

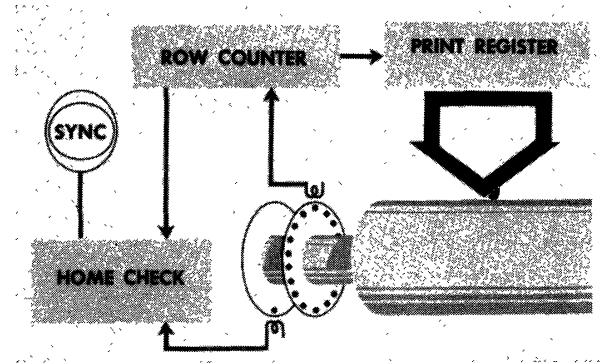

Fig. 15—Synchronization check.

Because of the versatility of the Burroughs 220 High-Speed Printer System, all operations must be programmed or wired. The operator effectively provides his own logical operations by wiring.

CONCLUSION

To summarize, the Burroughs 220 High-Speed Printer System offers a maximum of editing versatility with minimum plugboard wiring. More important, it allows swift, simple but complete rearrangement of buffer information—and eliminates the necessity for complex and time-consuming data shifting within the computer or the preparation of special print tapes.

Because of this flexibility and power, the printing problems of a wide range of applications can be solved with ease.

The ACRE Computer—A Digital Computer for a Missile Checkout System

RICHARD I. TANAKA†

INTRODUCTION

THE effectiveness of a missile system is directly dependent upon the proper assembly and subsequent reliability of its various subsystems. A supporting checkout system which enables rapid, consistent, and thorough testing of subsystems is an essential item in insuring the over-all operational success of a complex missile.

This paper describes a digital computer which is used as the central controller in an automatic checkout system. The system itself is called ACRE, for Automatic Checkout and Readiness Equipment; the computer is

referred to as the ACRE computer. The ACRE computer is, essentially, a general-purpose, stored-program digital computer; particular capabilities, however, have been emphasized to enable efficient operation of the checkout processes.

The computer and associated system are required to perform functions which can conveniently be grouped as follows:

- 1) Monitor key quantities which indicate the existence of conditions hazardous to the missile or to associated personnel.
- 2) Perform detailed checkout on a newly manufactured missile system to inspect for proper operation or to diagnose possible causes of malfunction.

† Lockheed Missiles and Space Div., Palo Alto, Calif.