

## THE NORDSIECK COMPUTER

Arnold Nordsieck  
University of Illinois  
Urbana, Illinois

### I Introduction

After some experience with a mechanical differential analyser of the Bush type<sup>1</sup>, the author became convinced that there was a need for a smaller, cheaper instrument of this type with a faster and more convenient setup procedure. The large instruments are so large and expensive mainly because of the torque amplifiers they contain and are somewhat inconvenient to use because, aside from considerations of accessibility to the individual researcher, they have rather long and complicated setup procedures.

The need for torque amplification can be eliminated by employing a mechanical integrator which will transmit appreciable torque without slipping at all. The author has developed such an integrator, which will be described in section II. Speed and convenience of setup can best be achieved by arranging to have all interconnections made electrically, and accordingly all the input and output variables of all the units (integrators, multipliers, adders, etc.) in the new instrument are converted into electrical form by synchro motors and generators<sup>2</sup> and made available at a plug board. The general size can also be kept small without prejudice to accuracy because the key parts can readily be machined to an accuracy of 0.001 inch and because the ultimate output consists of driving revolution counters or pushing pens across graph paper. These processes require negligible forces and torques, so that if care is taken not to dissipate torque needlessly in bearing friction or otherwise, very small motors can be used throughout. The torques employed in the new machine are in the range of one inch-ounce and the total mechanical driving power is less than 1/100 horsepower. The six-integrator machine is about the size of a desk and weighs about 500 lbs. and requires less than 500 watts of 110 volt 60 cycle power. The accuracy cannot be given in any absolute way since it depends on the problem being solved, but it is in the general range of one part in a thousand.

Further reduction in weight and size, for a given number of integrators and with no loss in accuracy, may be possible.

The original machine of this type has been in use at the University of Illinois, Urbana, Illinois for some time and replicas of it have been built and operated at Purdue University, Lafayette, Indiana, and at Radiation Laboratory, University of California, Berkeley, California. A wide variety of problems have been solved on the machines, ranging from stability of non-linear servos and design of non-linear springs to charged particle orbits in linear accelerators and problems in quantum mechanics and nuclear physics.

## II Mechanical Integrating Mechanism

From the arguments given in the introduction it follows that an integrating device to make the whole plan technically feasible ought to have three properties: It must work with shaft angles as variables so as to preserve the original inherent accuracy of the Bush machine, which derives from representing a unit of any variable by a large number of shaft revolutions; it must transmit appreciable torque without slipping; and it must fit in design-wise with synchro motors and generators without excessive dissipation of torque in bearing friction, etc.

The device used in the Bush machine<sup>1</sup> has a wheel with a fairly sharp edge, rigidly mounted on a shaft and driven by a smooth, hard flat turntable, and this device will not transmit appreciable torque without slipping. There is another commonly used integrating device, the turntable, ball and cylinder system invented by James Thompson<sup>3</sup> which will indeed transmit appreciable torque without slipping provided enough thrust is applied to the ball. The Thompson device requires several bearings in addition to the essential bearings of the input and output shafts, especially if much thrust is applied to the ball. Now the bearings in synchros are high quality anti-friction bearings, and since the synchros were to be an integral part of the design for other reasons, as outlined in the introduction, it seemed desirable entirely to avoid any additional bearings. This was accomplished by developing a kind of cross between the wheel-turntable device of the Bush machine and the cylinder-ball-turntable device of Thompson. In effect we redesign the wheel so that it behaves like a wheel and a ball simultaneously.

The sharp edged wheel rigidly mounted on its shaft cannot transmit appreciable torque without slipping, essentially because as the velocity ratio is varied (it must be varied continuously while the unit is running for integration to be performed) the wheel must slide over the turntable parallel to its own shaft. The ball of the Thompson device can transmit appreciable torque, essentially because it engages in pure rolling motion even when the velocity ratio is continuously varying. Therefore if we alter the wheel by mounting it ball-and-socket wise on its shaft and making its rim part of a spherical surface we have a device of the simplicity of the wheel-turntable device and with the pure rolling property of the Thompson device.

The Figure shows a schematic diagram of the integrating wheel and of its relationship to the smooth hard flat turntable or disc, which is common to all such devices. The wheel is mounted on its shaft by a ball and socket joint which is a lubricated free sliding fit. The ball is rigidly fixed to the shaft. A pin projecting radially from the ball slides between a pair of pins mounted axially in the wheel, thus keying the wheel to the shaft. Hence the wheel is free to turn, relative to the shaft, about any axis

normal to the shaft within limits set by a stop. On the other hand rotation of the wheel about the shaft axis is positively communicated to the shaft. The whole attachment of the wheel to its shaft is equivalent to what is normally called a universal joint of limited misalignment.

The rim of the wheel is part of a spherical surface with center coinciding with the center of the ball. This surface must be accurate and hard.

Several springs are fastened to the wheel shaft and bear on the wheel near its rim in such a way as to tend to straighten the wheel up. The tension in these springs is adjusted so that in operation they are able to rotate the wheel about an axis through the point of contact and the center of the ball but are not strong enough to slide the wheel on the turntable.

The value of the "integrand" in the operation of integration is represented by the distance from the axis of the turntable to the point of contact, labelled "d" in the Figure. If we imagine that the turntable axis is fixed and that the wheel shaft is moved any given distance parallel to itself, then because of the spherical form of the wheel rim the point of contact will move an exactly equal distance; consequently "d" will change by the same distance. In practice we move the turntable and hold the wheel shaft longitudinally fixed, but the net effect is the same. If enough normal thrust is applied to the point of contact through the shaft bearings the wheel will engage in pure rolling motion so long as it clears the stop. In actual operation the distance "d" varies and the wheel shaft rotates simultaneously, and the change in "d" per quarter revolution of the wheel shaft is small compared to the radius of the wheel. Therefore the tilt or nutation of the wheel introduced by the variation of "d" is continuously carried around and wiped out by the action of the springs. Consequently in operation the wheel departs from its square position by barely visible amounts and rarely comes near the stop. An exception to this normal condition occurs when "d" is near zero since then the rate of rotation of the wheel shaft is very small and the tilt of the wheel may accumulate considerably before it is carried round and nullified by the springs. The width of the wheel rim and the clearance of the stop have been so chosen that the wheel is rarely brought up against the stop even when traversing through the position "d" = 0. Occasional contact with the stop and corresponding momentary slippage at the point of contact are not serious because the error thus introduced is proportional to the fraction of the time that slipping occurs.

When this integrating wheel is to be used to drive a synchro generator (the "integral synchro" of the integrator) the diameter of the wheel is chosen slightly larger than the diameter of the

body of the synchro and the wheel is mounted directly on the synchro shaft close up to the front bearing. No additional bearings over and above the synchro bearings are employed.

### III General Description of Computer

Generally speaking the computer consists of a collection of independent units mounted together on a rolling table, most of these units being supplied in multiple, for mechanically performing the elementary operations which in combination enable one to solve a system of ordinary differential equations. These units are integrators, multipliers for multiplying any variable by a chosen constant, adders, plotting tables for reading functional relationships graphically into or out of the computer, a motor-driven independent variable unit for turning the independent variable shafts, hand cranks for turning any shaft by hand as in manual curve following, and revolution counters for indicating the numerical value of any chosen variable. At present we put on one rolling table six integrators, six multipliers, four adders, two plotting tables, one independent variable unit, two or three hand cranks and two revolution counters. The two last mentioned counters are in addition to the revolution counters fitted to the integrand synchro shafts on the integrators. A six integrator unit can be used alone for relatively small problems or several of them can be combined into a computer of larger capacity. As indicated earlier, all the input and output variables of all these units are brought to a master plug board in electrical synchro form. The operation of setting up or clearing out a problem involves only plugging up or clearing out a set of connections on the plug board and manually selecting the gear ratios on the multipliers.

The integrators have an integrator factor of  $1/60$ , i.e. if the integrand is set at one shaft revolution the velocity ratio is  $1/60$ . The range of the integrand is from minus 60 to plus 60 turns (with some leeway), significant to  $1/20$  turn.

The multipliers make gear ratios of 0.1, 0.2, . . . 0.9 available by manual selection.

An adder consists of a differential synchro driving an ordinary synchro.

The plotting tables have lead screws of 20 threads per inch and are designed for use with standard  $1/20$  inch graph paper, 7 inch by 10 inch grid on  $8\frac{1}{2}$  inch by 11 inch paper. Each table may be used for either input or output as desired.

The computer is provided with several types of protective circuits which make it essentially fool proof in the sense that the operator can spoil a problem solution but cannot damage the

computer by incorrect connections or operation. Each synchro is provided with a protective ballast lamp and condenser combination which warns the operator and reduces the energizing voltage to prevent burnout if that machine is desynchronized. For each lead-screw driven element a warning light is provided to indicate when it is near the mechanical limits of its travel and the drive is completely disconnected before these limits are reached. The integrating wheels are kept disengaged except when a problem solution is actually being run in order to permit synchronizing the synchros and setting initial values of integrands without sliding of the wheels on the turntables.

References

1. V. Bush, "The Differential Analyser, a New Machine for Solving Differential Equations," Journal Franklin Institute vol 212, p 447, 1931.  
 V. Bush and S.H. Caldwell, "A New Type of Differential Analyser," Journal Franklin Institute vol 240, No. 4, 1945.  
 J. Crank, "The Differential Analyser," Longmans Green and Co., London, 1947.  
 A.C. Cook and F.J. Maginniss, "Applications of the Differential Analyser," General Electric Review vol 52, p 14, 1949.
2. L.F. Holder, "Principles of Selsyn Equipments and Their Operation," General Electric Review vol 33, p 500, 1930.  
 H.W. Reding, "Synchronized Drives without Mechanical Connection," Electric Journal vol 33, p 277, 1933
3. James Thompson, Proceedings of the Royal Society, vol 24, p 262, 1876.

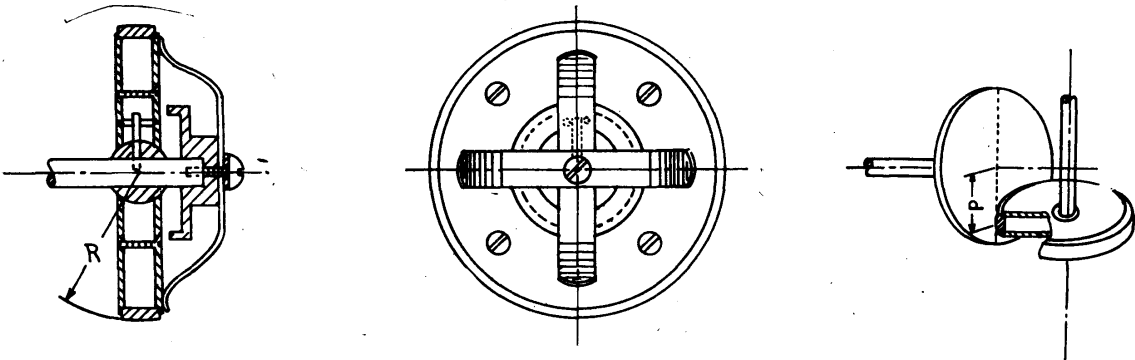

Fig. 1 - Schematic Diagram of Integrating Wheel.